

ENGINE

RIGHT PRIMARY TIMING CHAIN (G222806)

IN-VEHICLE REPAIR

12.65.66	TIMING CHAIN - PRIMARY - BANK 1 - RENEW	ALL DERIVATIVES	5.00	USED WITHINS
----------	-----------------------------------------	-----------------	------	--------------

12.65.66	TIMING CHAIN - PRIMARY - BANK 1 - RENEW	ALL DERIVATIVES	5.00	USED WITHINS
----------	-----------------------------------------	-----------------	------	--------------

SPECIAL TOOL(S)

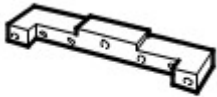

E36401

JD 215

Camshaft setting



E36402

JD 217

Timing chain tensioning



E36407

JD 218

Wedges, primary chain



E30408

JD 216

Crankshaft setting

REMOVAL

1. Open the engine compartment and install paintwork protection sheets.
2. Set the engine compartment cover to the service access position.
3. Open the driver's door, or both doors if necessary, to allow the side glass to drop. Make sure that the doors remain open until after the battery has been disconnected.

4.

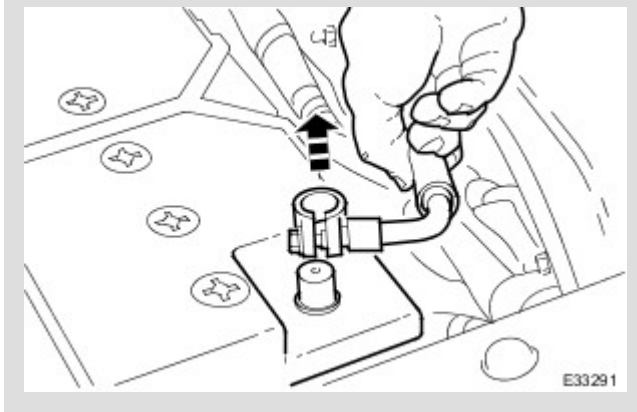

Disconnect the battery ground cable.

Remove the battery cover.

5. Remove the engine front cover. For additional information, refer to: [Engine Front Cover](#) (303-01 Engine, In-vehicle Repair).

6.

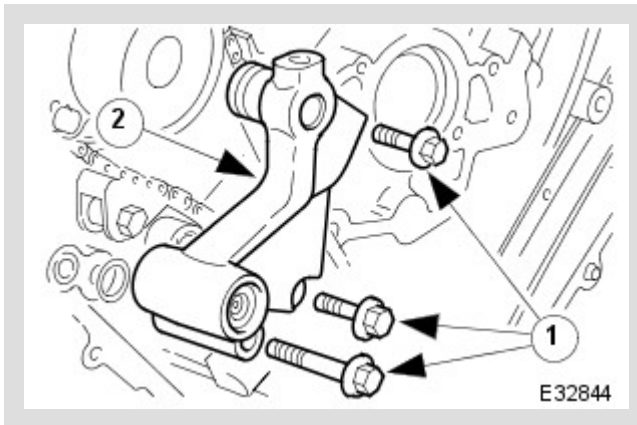

Remove the VVT bush carrier.

1. Remove the three bolts which secure the carrier to the cylinder block.
2. Release the carrier from the two ring dowels and remove it.

7.

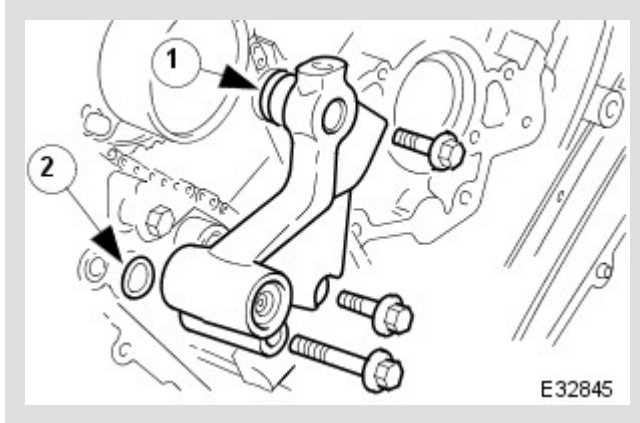

Remove the seals from the bush carrier.

1. Remove the sealing ring (scarf jointed) from the carrier bush groove.
2. Remove the O-ring from the carrier oil-way recess.

8. Raise the vehicle on a ramp.

9.

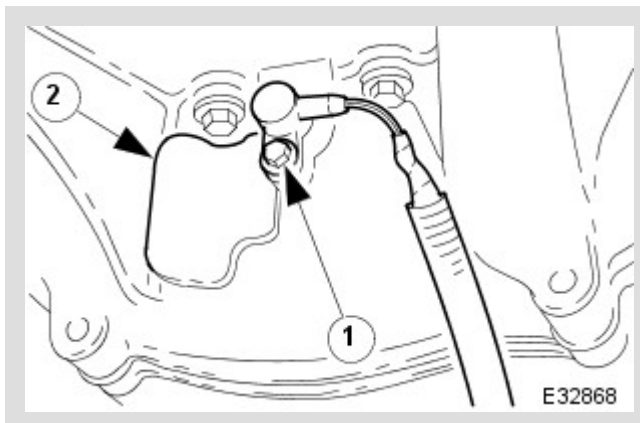

Remove the crankshaft position sensor.

1. Remove the bolt which secures the crankshaft position sensor to the flywheel housing.
Remove the sensor and allow it to hang free under the engine.
2. Remove the access grommet (for torque converter bolts) from the housing.

10. Install the damper securing bolt (old one) to the crankshaft, hand-tight only.

11.

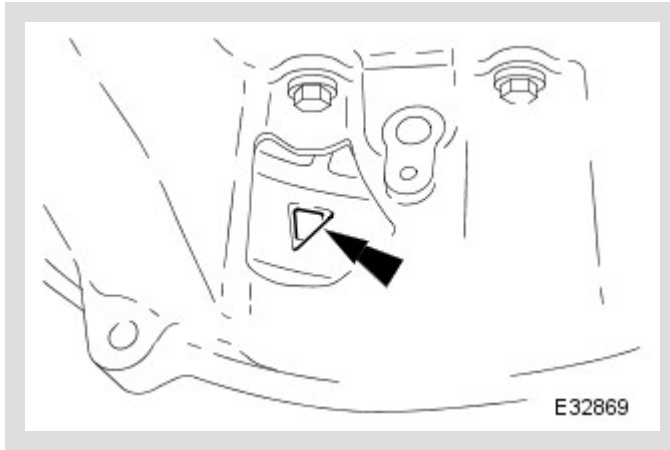

Rotate the crankshaft until the triangular arrow indent on the drive plate is visible through the access hole; confirm that the timing flat on each camshaft is uppermost.

12.

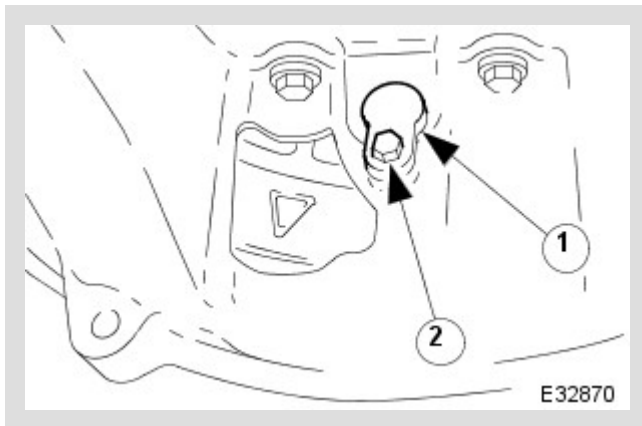

Install the crankshaft setting peg JD 216 to the crankshaft position sensor location.

1. Install the crankshaft setting peg JD 216.

Position the crankshaft so that the setting peg engages fully into the timing slot.

2. Install and tighten the bolt to secure the setting peg.

13. Remove the damper securing bolt from the crankshaft.

14. Lower the vehicle on the ramp.

15.

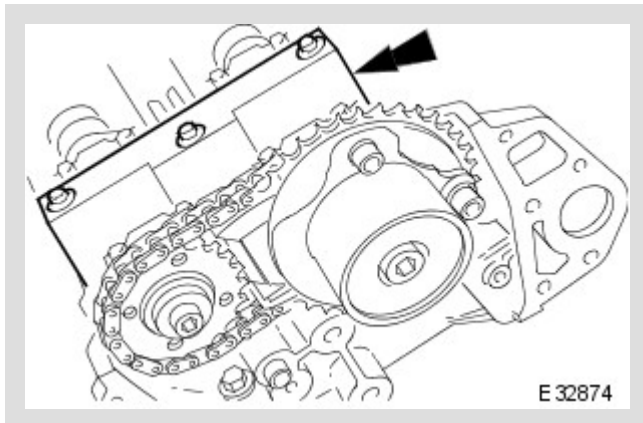

Install the camshaft locking tool JD 215 to the RH camshafts, aligning the shafts slightly as necessary.

16.

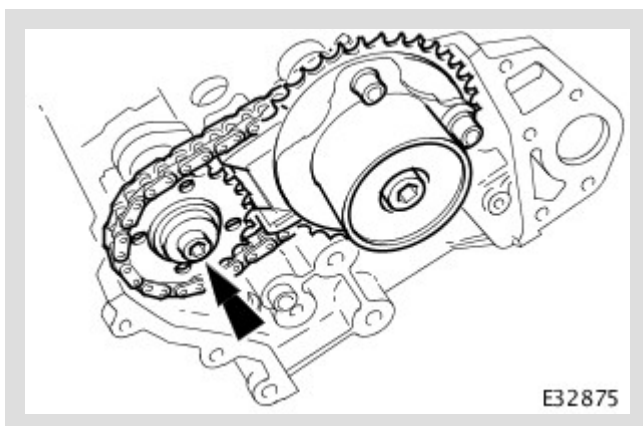

Loosen the bolt which secures the sprocket to the camshaft.

17.

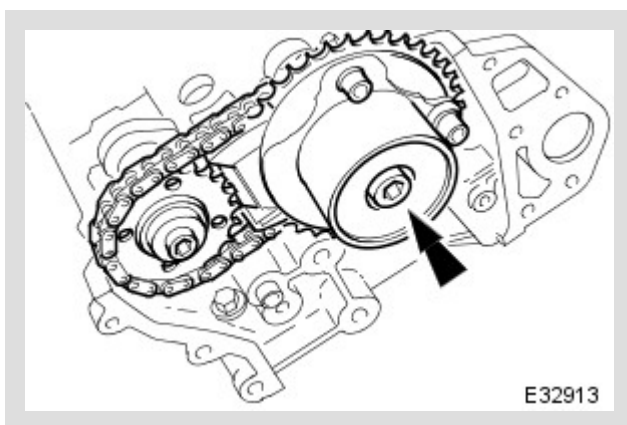

Loosen the bolt which secures VVT unit to the camshaft.

18.

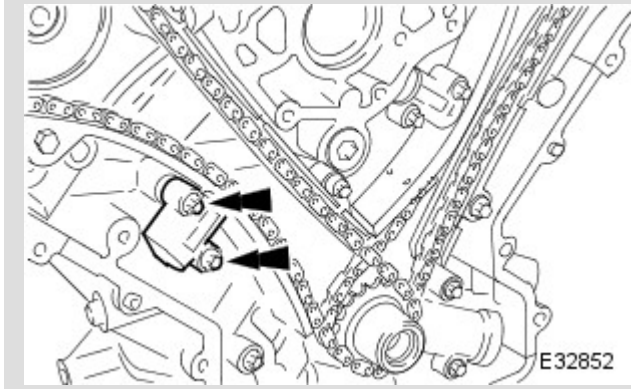

Remove the primary chain tensioner bolts.

19.

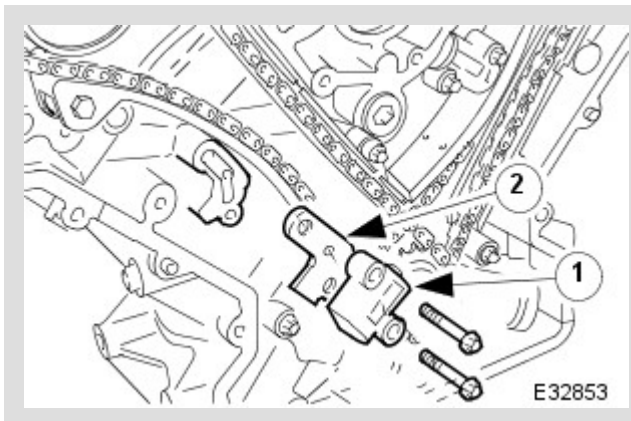

Remove the tensioner assembly.

1. Remove the tensioner.
2. Remove the tensioner back-plate.

20.

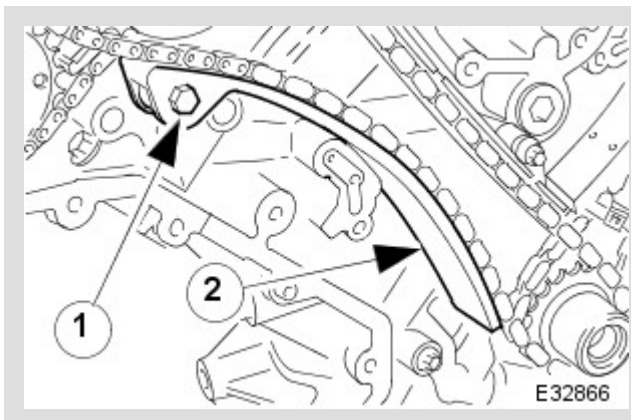

Remove the chain tensioner blade.

1. Remove the pivot bolt which secures the tensioner blade.
2. Remove the tensioner blade.

21. Remove the chain from the VVT unit and from the crankshaft sprocket.

22.

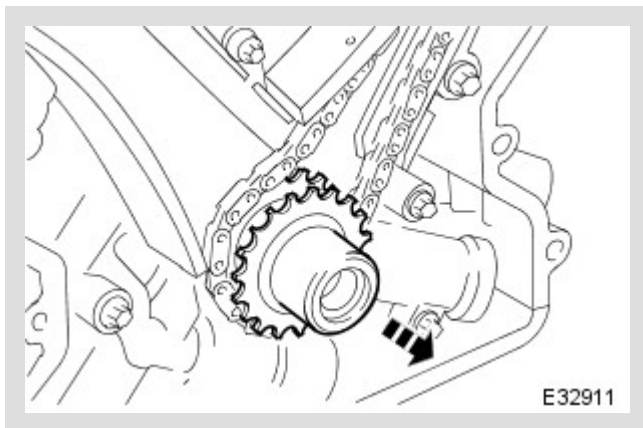

If necessary, remove the sprocket from the crankshaft.

Note the orientation of the sprocket relative to the sprocket for the RH drive (half a tooth out of line) and remove the sprocket.

23. Clean and inspect all relevant components.

INSTALLATION

1.

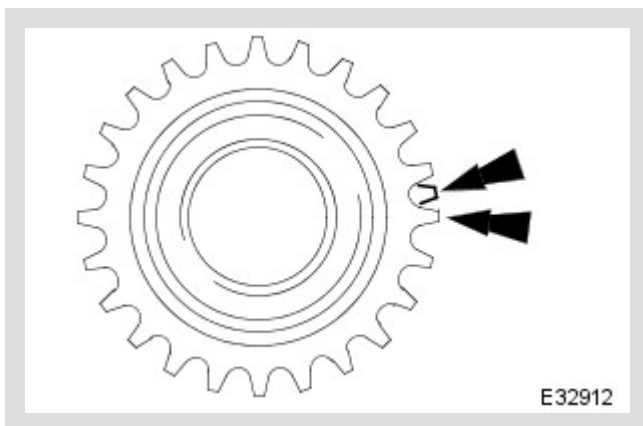

If removed previously, install the sprocket to the crankshaft.

The teeth of the RH and the LH sprockets on the crankshaft must be out of phase with each other. If they are in-phase after installing, remove the sprocket, turn it on its vertical axis and install it.

2.

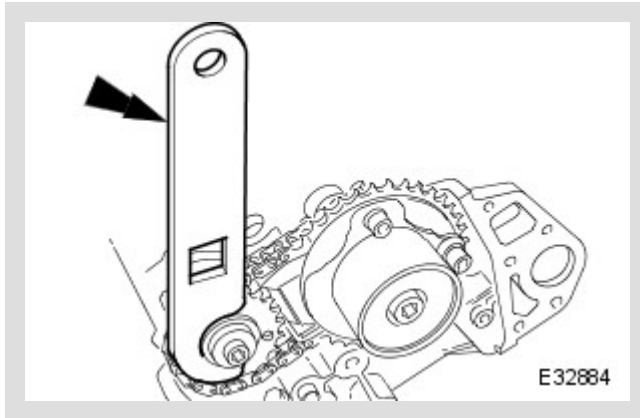

Install the chain tensioning tool JD 217 to the exhaust camshaft sprocket.

Reposition the sprocket (and the VVT unit) for the most advantageous position for use of the tool.

Remove the tool.

3.

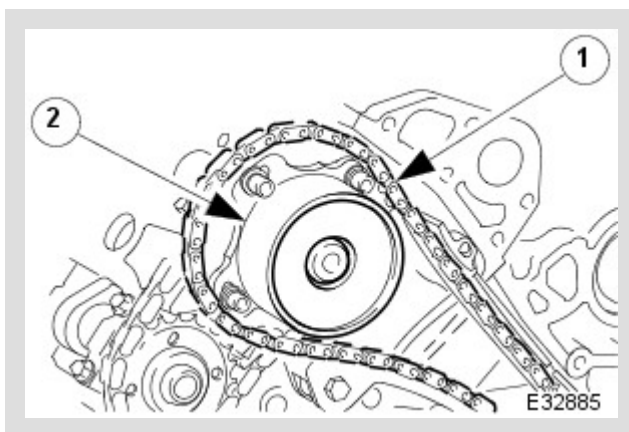

Install the primary timing chain.

1. Install the primary chain to position over the crankshaft sprocket and the VVT unit sprocket. There must be no slack on the drive side of the primary chain and the VVT unit must not be rotated on the camshaft.

4.

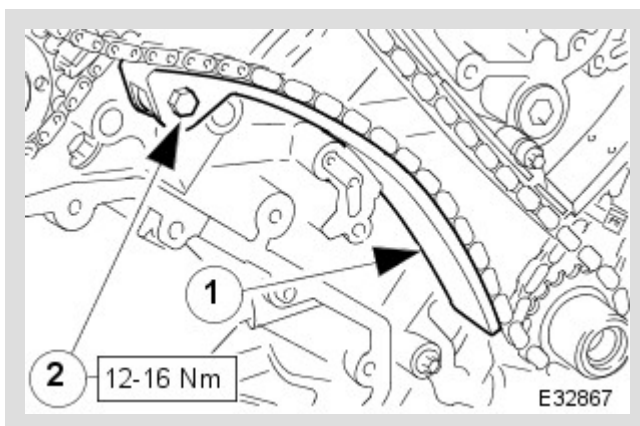

Install the primary chain tensioner blade.

1. Position the tensioner blade to the cylinder block.
2. Install the retaining / pivot bolt and tighten it to 14 Nm.

5.

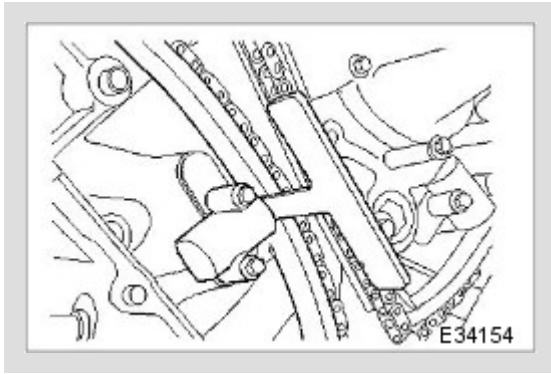

Install the primary chain tensioner assembly.

Use a wedge JD 218 (or two if required) between the primary chain tensioner and tensioner blade, to take up the slack in the chain.

6.

⚠ CAUTION:

Make sure that a new bolt is installed.

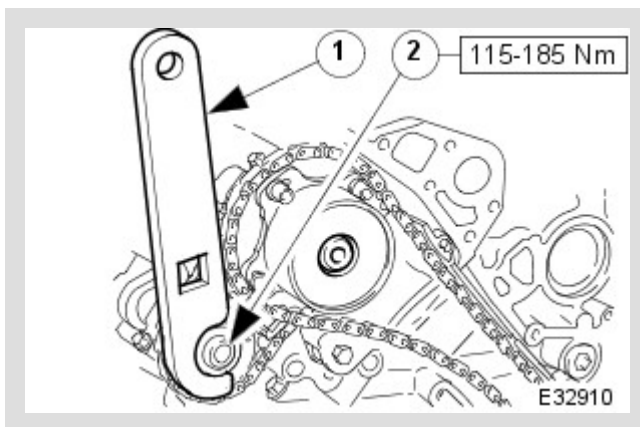

Tighten the exhaust camshaft sprocket securing bolt.

1. Install the chain tensioner tool JD 217 to the sprocket holes.

Apply force to the tool in an anti-clockwise direction to tension the chain on its drive side.

2. Whilst applying the opposing force to the sprocket and chain, tighten the sprocket securing bolt to 20 Nm + 90°.

7.

⚠ CAUTION:

Make sure that a new bolt is installed.

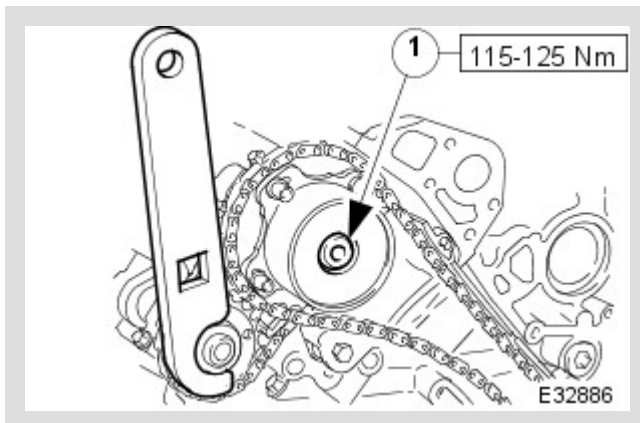

Tighten the VVT unit securing bolt.

1. Whilst still applying the opposing force to the sprocket and chain (using JD 217), check that the wedges are still in place, tighten the VVT unit securing bolt to 20 Nm + 90°.

Remove the chain tensioning tool and the wedge(s).

8. Remove the camshaft locking tool JD 215.

9. Raise the vehicle on the ramp.

10. Remove the crankshaft setting tool JD 216.

11.

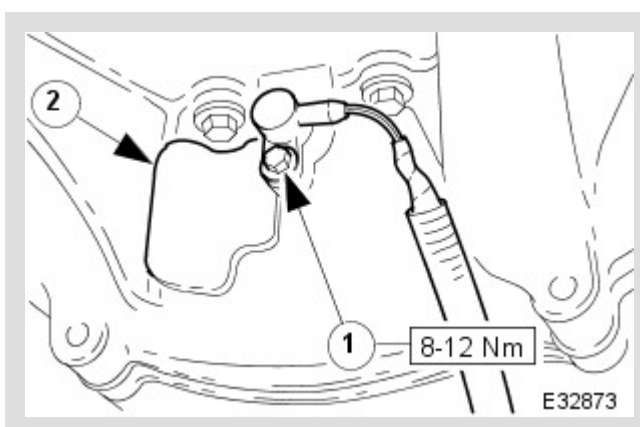

Install the crankshaft position sensor.

1. Install the sensor to the flywheel housing and install the securing bolt. Tighten to 10 Nm.
2. Install the access grommet to the housing.

12. Lower the ramp.

13.

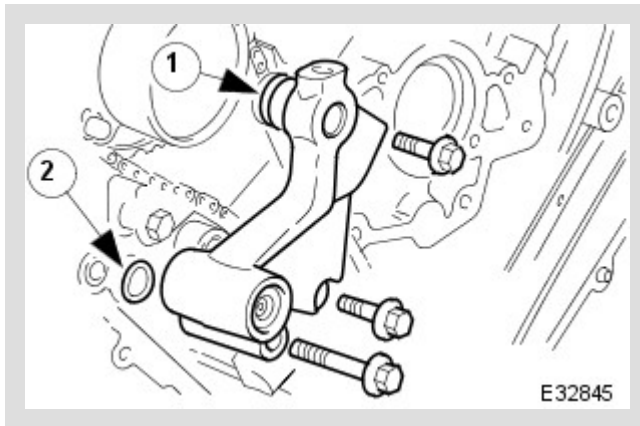

Install new seals to the VVT bush carrier.

1. Install the new sealing ring (scarf jointed) to the carrier bush groove.
2. Install a new O-ring to the carrier oil-way.

14.

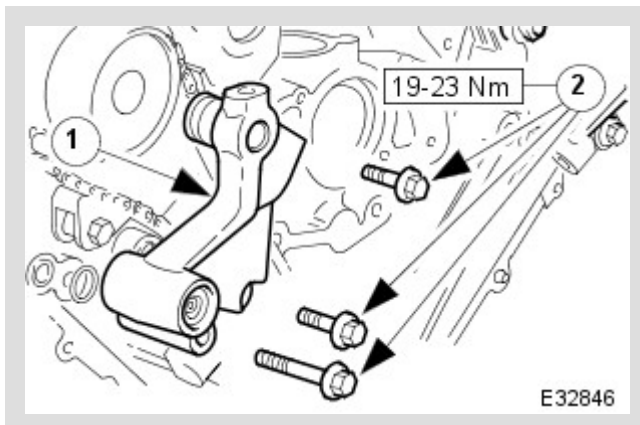

Install the VVT bush carrier to the cylinder block.

Lubricate the seal (scarf jointed) and the bush.

1. Install the bush carrier assembly.

Check that the seals are in place and that the ring dowels are engaged squarely. Fully locate the assembly as much as possible by hand pressure.

2. Install the three securing bolts. Tighten to 21 Nm.

15. Install the engine front cover. For additional information, refer to: [Engine Front Cover](#) (303-01 Engine, In-vehicle Repair).

16. Move the engine compartment cover from the service position and connect the gas struts.

17. Remove the paint protection sheets and close the cover.

18. Connect the battery and install the battery cover. For additional information, refer to: [Battery Connect](#) (414-01 Battery, Mounting and Cables, General Procedures).

PUBLISHED: 11-MAY-2011
1997.0 X100, 414-01

BATTERY, MOUNTING AND CABLES

BATTERY CONNECT [G222938]

GENERAL PROCEDURES

1.



NOTE:

Whether one, or both, cables are disconnected, a minimum of 30 seconds MUST elapse between disconnection of the FIRST cable and reconnection of the LAST cable. A clean final connection must be made; do not allow temporary contact.

Connect the battery terminal(s).

2. Reset the clock.

3. Enter the radio security code. If necessary, refer to the Sound System Handbook.

4. Cycle (both) door drop glass up and down to establish the upper and lower datum points.

Switch the ignition ON .

Lower the glass to the stop and hold the switch in the DOWN position for a further five seconds.

Raise the glass fully and hold the switch in the UP position for a further five seconds.

5. Switch the ignition OFF .

PUBLISHED: 11-MAY-2011
1997.0 X100, 303-01

ENGINE

ENGINE FRONT COVER [G222793]

IN-VEHICLE REPAIR

12.65.01	TIMING COVER - RENEW	ALL DERIVATIVES	4.40	USED WITHINS
-----------------	-----------------------------	------------------------	-------------	---------------------

12.65.01	TIMING COVER - RENEW	ALL DERIVATIVES	4.40	USED WITHINS
-----------------	-----------------------------	------------------------	-------------	---------------------

REMOVAL

1. Open the engine compartment and fit paintwork protection sheets.

2. Set the bonnet to the service access position.

3.

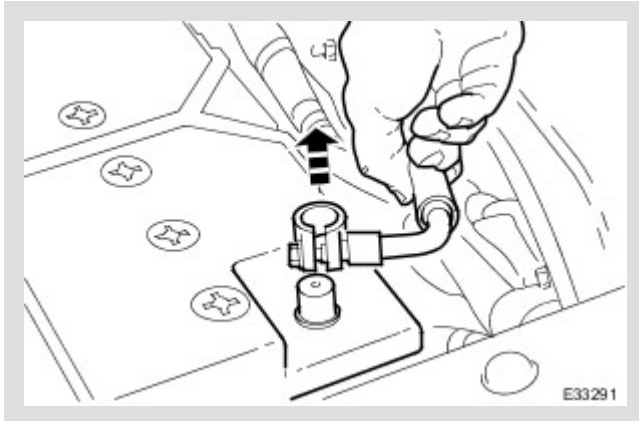

Disconnect the battery ground cable.

Remove the battery cover.

4. Drain the coolant from the radiator. Refer to Operation 26.10.01.

5.

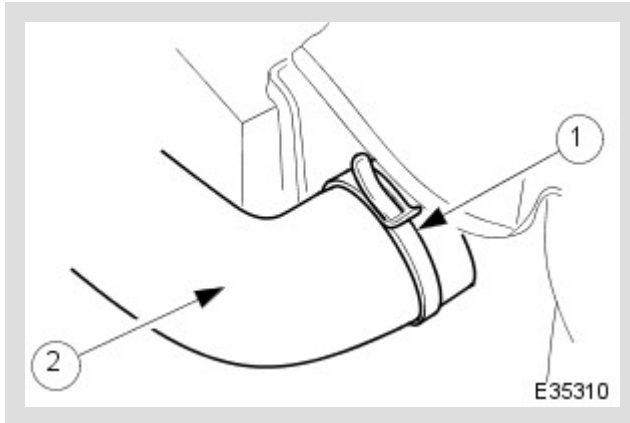

Disconnect the radiator top hose.

1. Slacken the hose retaining clip and reposition the clip along the hose.
2. Disconnect the hose from the radiator.

6.

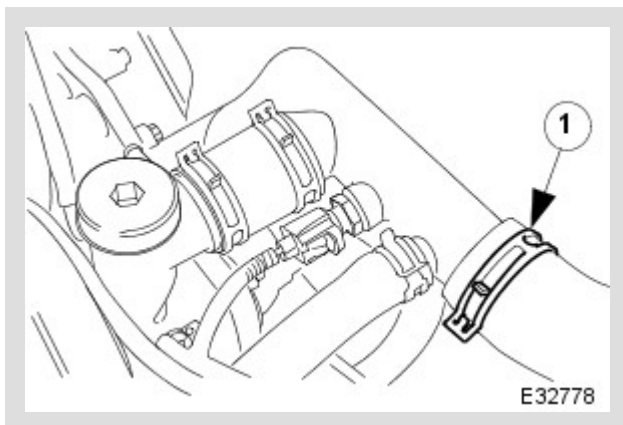

Disconnect the top hose from the coolant outlet pipe.

1. Release and reposition the hose clip, and disconnect the top hose.

7.

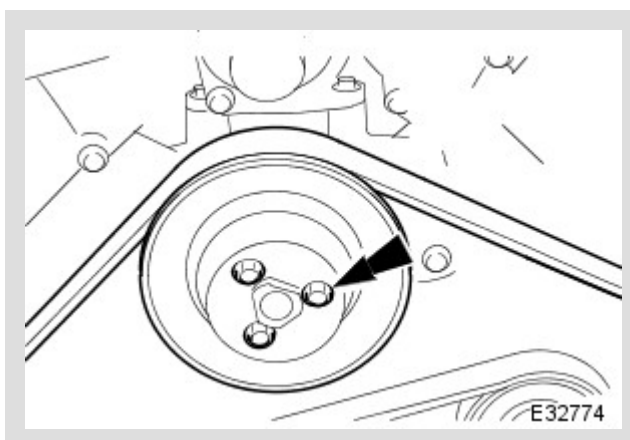

Slacken the three screws which secure the water pump pulley.

8.

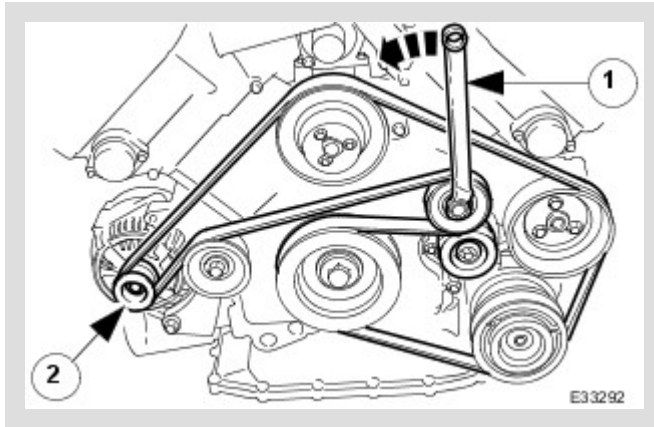

Remove the drive belt from the generator and accessory drive.

1. Use a spanner e.g. Churchill JD-230 or Snap On XDHM 1415, on the centre bolt of the belt tensioner idler pulley, to turn the adjuster assembly to the left against spring tension.
2. Whilst holding the tensioner against spring tension, remove the drive belt from the generator pulley. Release the tensioner slowly and remove the spanner.
Disconnect the belt from the other pulleys and remove it..

9.

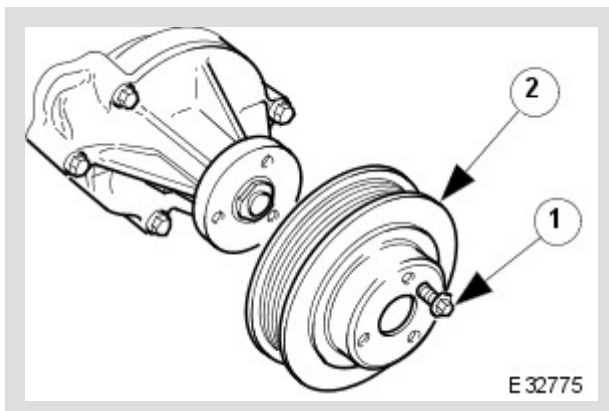

Remove the pulley from the water pump.

1. Remove the pulley securing screws.
2. Remove the pulley from the water pump.

10. Remove the belt tensioner assembly, from the Front Accessory Drive. Refer to Operation 12.10.41.

11. Remove the idler pulley, from the Front Accessory Drive. Refer to Operation 12.10.43.

12. Remove the crankshaft damper. Refer to Operation 12.21.09.

13. Carefully remove the engine covers, taking care not to damage the plastic fixings or the rubber inserts.

14.



Disconnect the intake tube from the throttle body.

1. Remove the two bolts which secure the intake tube to the throttle body.
2. Disconnect the intake tube from the throttle body.

15.

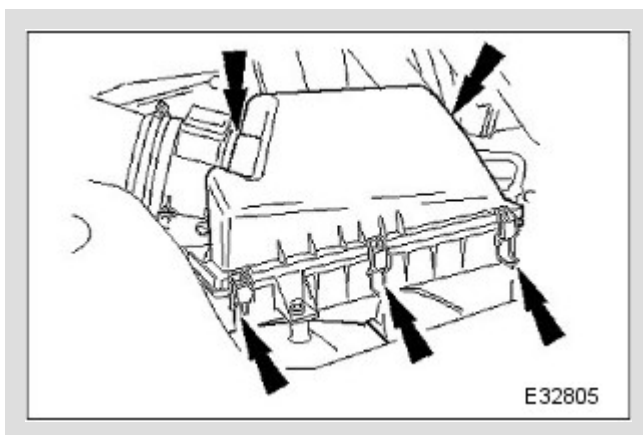

Disconnect the air cleaner cover.

Release the five clips which secure the air cleaner cover.

16. Disconnect the air flow meter multi-plug.

17.

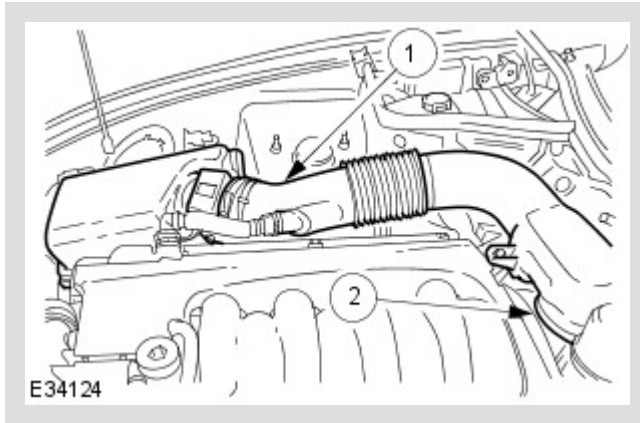

Remove the intake tube / air flow meter / air cleaner cover assembly.

1. Remove the intake tube / air flow meter / air cleaner cover assembly.
2. Remove and discard the rubber seal; air intake tube to throttle body.

18. Remove the purge valve, from the evaporative control system. Refer to Operation 17.45.01.

19. Remove the on-plug ignition coils. Refer to Operation 18.20.41 and 18.20.42.

20. Remove the camshaft covers. Refer to Operations 12.29.43 and 12.29.44.

21. Remove the variable valve timing solenoids. Refer to Operation 18.30.63.

22.

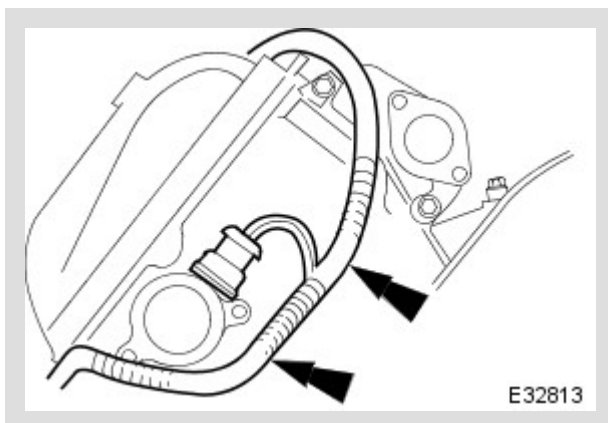

Disconnect the engine harness retaining clips from the timing cover.

23.

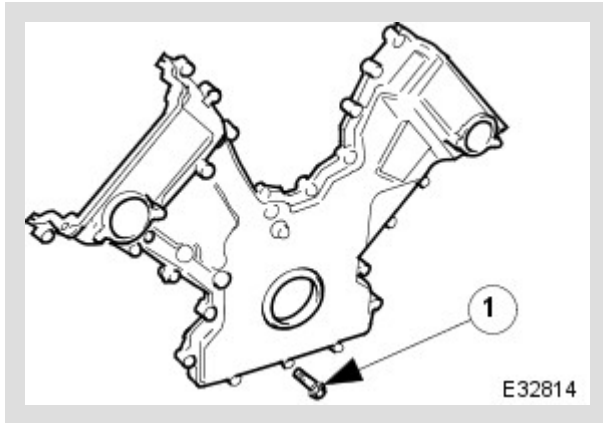

Remove the timing cover securing bolts.

1. Remove the twenty-four bolts which secure the timing cover.

24.



Remove the timing cover, step 1.

Ease the cover towards the front of the vehicle to separate it from the engine.

25.



Remove the timing cover, step 2.

Standing at the right hand side of the vehicle, rotate and manoeuvre the cover upwards to clear the water pump and hoses.

26.

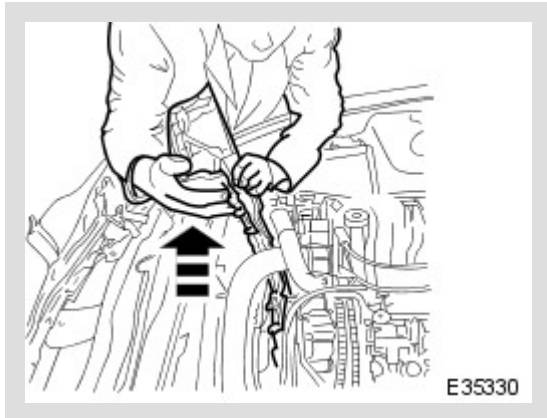

Remove the timing cover, step 3.

Lift the cover clear of the engine compartment.

27.

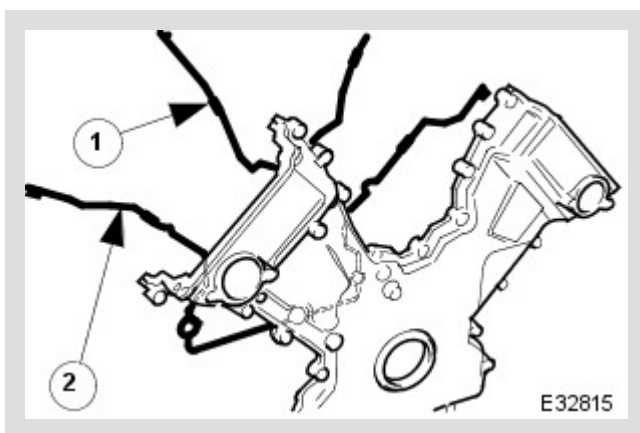

Remove and discard the inner and outer seals from the timing cover.

1. Remove the seal from the inner groove on the face of the timing cover.
2. Remove the seal from the outer groove on the face of the timing cover.

28. Clean all parts and mating faces.

INSTALLATION

1.

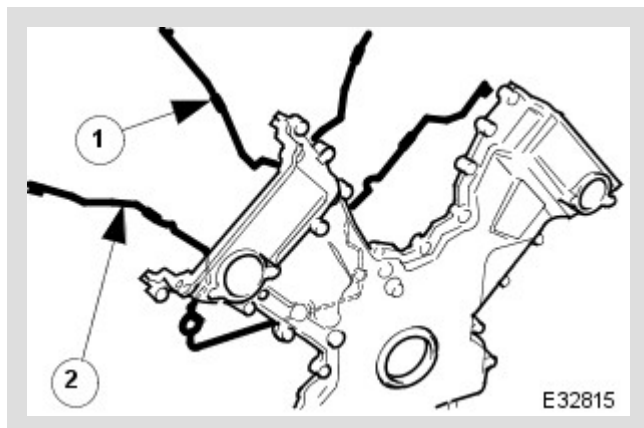

Fit new seals to the timing cover.

1. Fit and fully locate, a new seal to the inner groove on the face of the timing cover.
2. Fit and fully locate, a new seal to the outer groove on the face of the timing cover.

2.

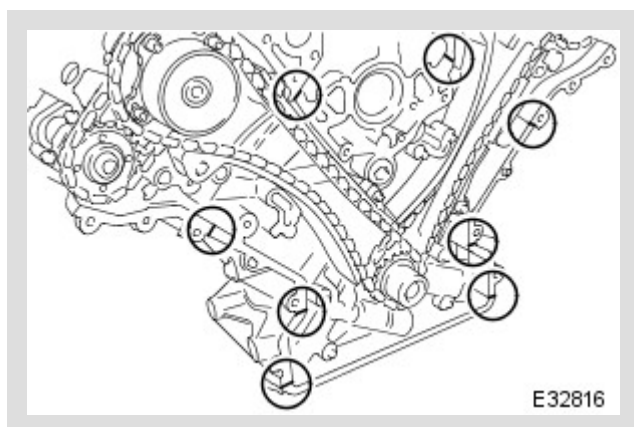

Apply sealant to the eight joints on the engine face.

Sealant beads to be 3mm diameter and 12mm long. Cut the nozzle of the sealant tube to produce a 3mm bead. (Fit and tighten the securing bolts within twenty minutes of sealant application)

3.

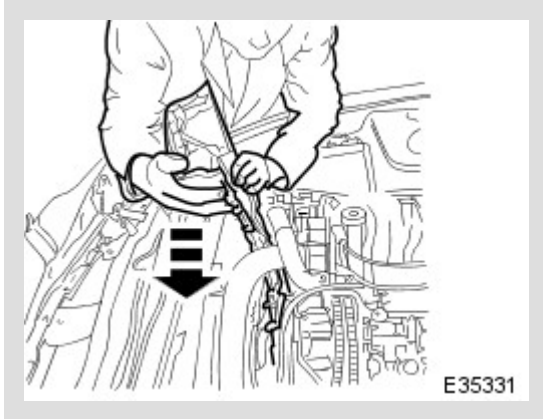

Refit the timing cover, step 1.

Lower the cover into the engine compartment, to its approximate position.

4.



Refit the timing cover, step 2.

Standing at the right hand side of the vehicle, rotate and manoeuvre the cover downwards to clear the water pump and hoses.

5.



Refit the timing cover, step 3.

Ease the cover towards the engine and locate it directly onto the dowels so that the gaskets or sealant are not smeared.

6.

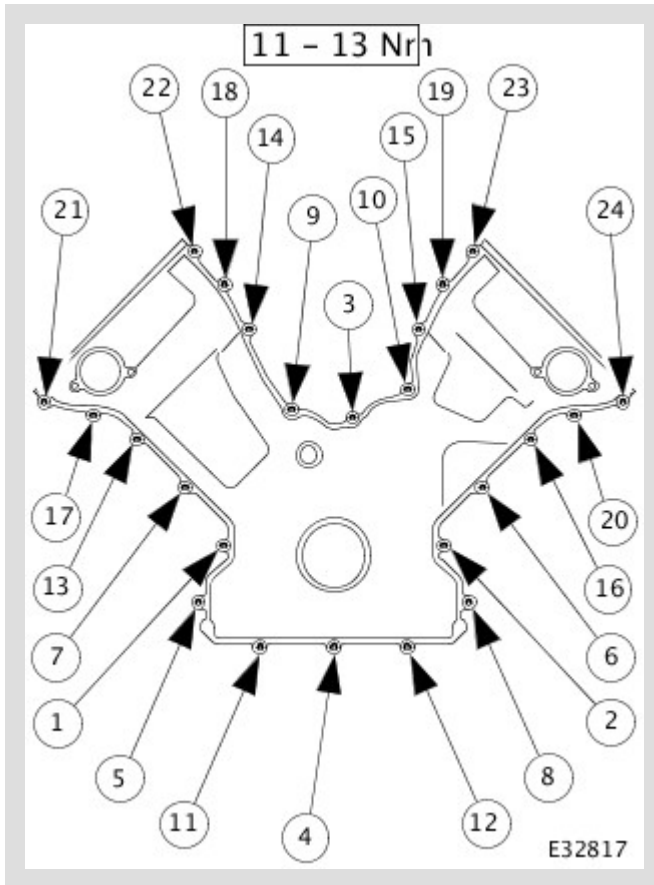

Fit and tighten the securing bolts in the correct order. Tighten to 11-13 Nm.

7.

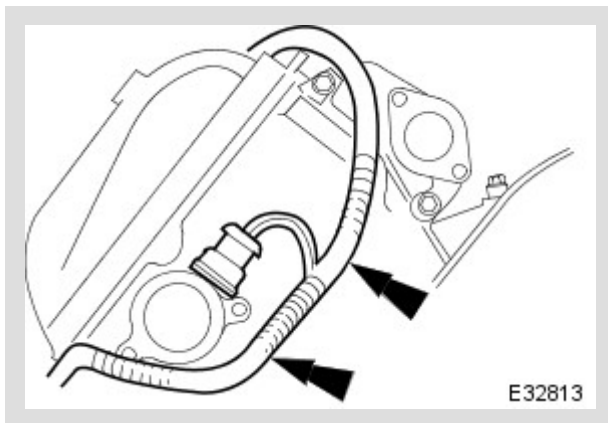

Reposition and secure the engine harness clips to the timing cover.

8.

Refit the variable valve timing solenoids. Refer to Operation 18.30.63.

9.

Refit the camshaft covers. Refer to Operations 12.29.43 and 12.29.44.

10.

Refit the on-plug ignition coils and coil covers. Refer to Operation 18.20.41 and 18.20.42.

11.

Refit the purge valve. Refer to Operation 17.45.01.

12.

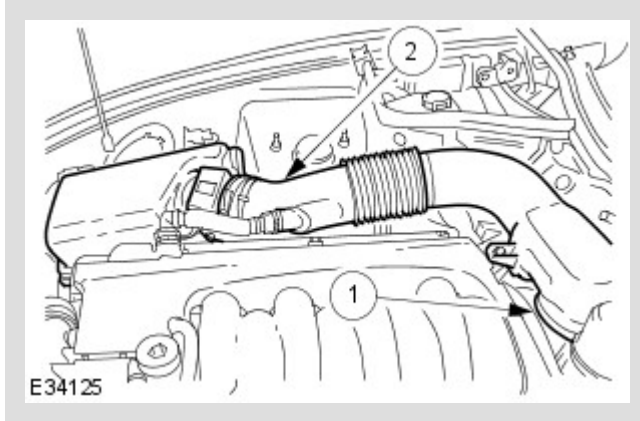

Fit the intake tube / air flow meter / air cleaner cover assembly.

1. Fit a new rubber seal; air intake tube to throttle body.
2. Fit the intake tube / air flow meter / air cleaner cover assembly.

13.

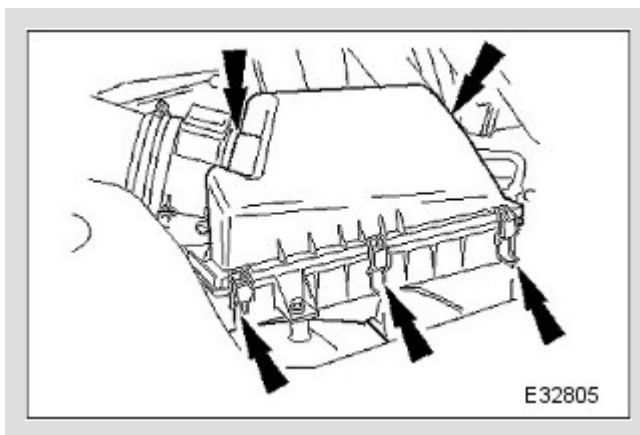

Reconnect the air cleaner cover.

Fit the five clips which secure the air cleaner cover.

14.

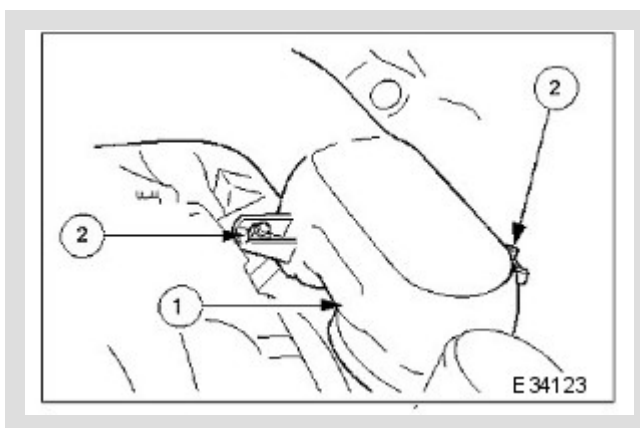

Connect the intake tube to the throttle body.

1. Connect the intake tube to the throttle body.
2. Fit the two bolts which secure the intake tube to the throttle body.

15. Reconnect the air flow meter multi-plug.

16. Refit the engine covers.

17. Refit the crankshaft damper. Refer to Operation 12.21.09.

18. Refit the idler pulley, to the Front Accessory Drive. Refer to Operation 12.10.43.

19. Refit the belt tensioner assembly, to the Front Accessory Drive. Refer to Operation 12.10.41.

20.

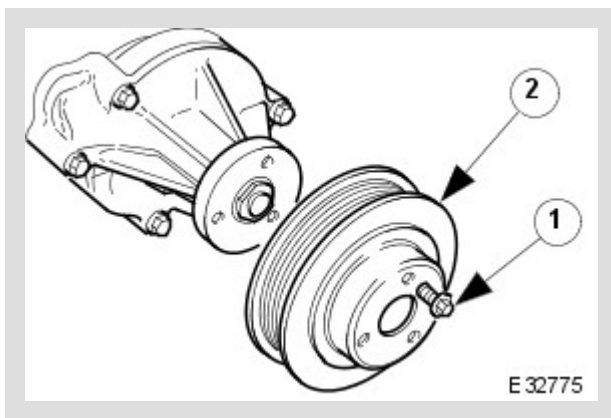

Refit the pulley to the water pump.

1. Refit the pulley to the water pump.
2. Fit the pulley securing screws. Tighten as far as possible; then to the correct torque after the belt has been fitted.

21.

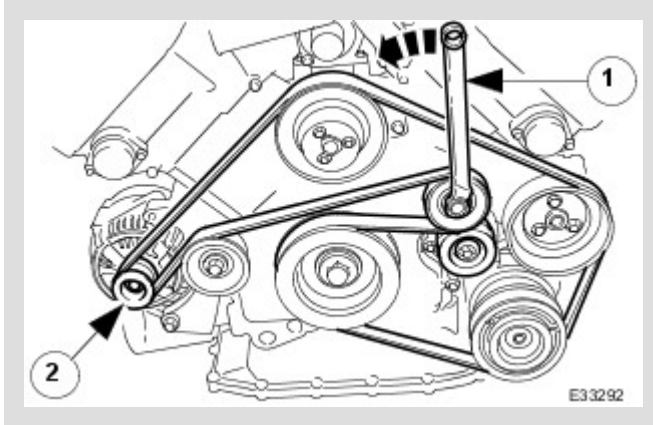

Refit the drive belt to the generator and accessory drive.

Locate the belt around the pulleys, except the generator pulley.

1. Use a spanner e.g. Churchill JD-230 or Snap On XDHM 1415, on the centre bolt of the belt tensioner idler pulley, to turn the adjuster assembly to the left against spring tension.
2. Whilst holding the tensioner against spring tension, connect the drive belt to the generator pulley. Release the tensioner slowly and remove the spanner.

22.

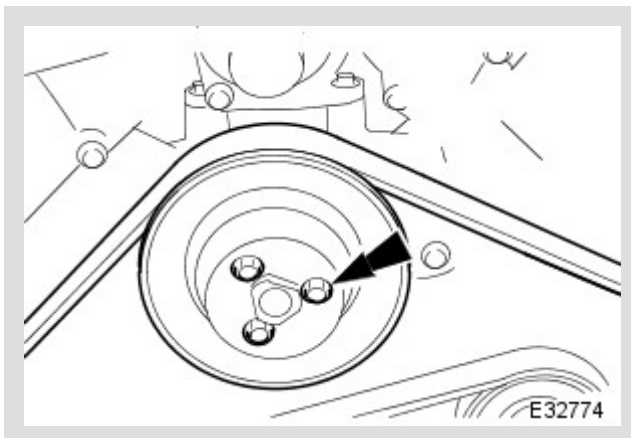

Tighten the three screws which secure the water pump pulley, to 10-14 Nm.

23.

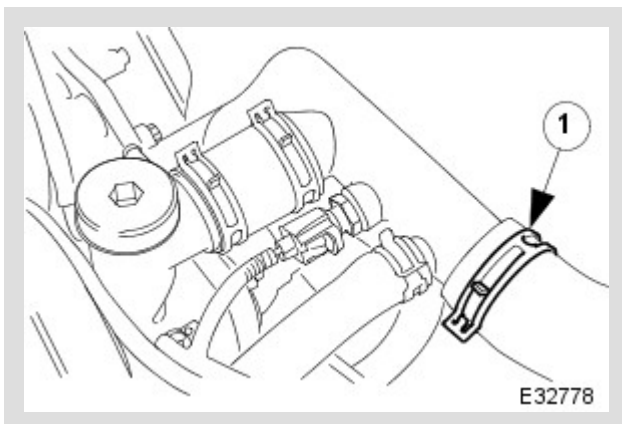

Connect the top hose to the coolant outlet pipe.

1. Connect the top hose. Reposition the hose clip and tighten.

24.

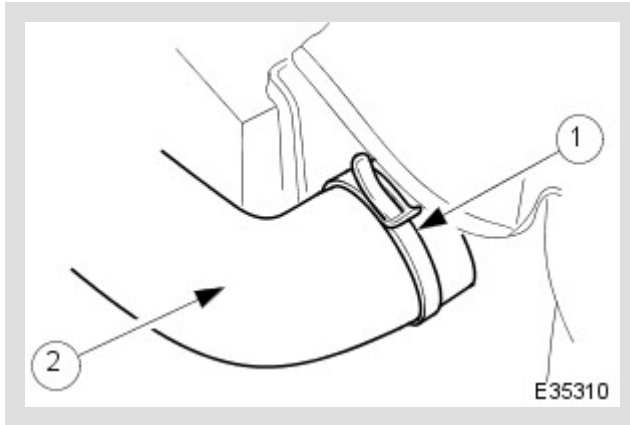

Connect the radiator top hose.

1. Connect the hose to the radiator.
2. Reposition the clip along the hose and tighten the clip.

25. Reset the bonnet to the normal position and connect the gas struts.

26. Connect the battery and fit the battery cover.

Refer to the Battery Reconnection Procedure 86.15.15.

27. Refill the cooling system. Refer to Operator 26.10.01.

28. Remove the paintwork protection sheets and close the engine compartment.