

ENGINE

INTAKE CAMSHAFT RH [G222801]

IN-VEHICLE REPAIR

12.13.14

**INTAKE
CAMSHAFT -
BANK 1 -
RENEW**

**ALL
DERIVATIVES**

6.30

USED WITHINS

12.13.14

**INTAKE
CAMSHAFT -
BANK 1 -
RENEW**

**ALL
DERIVATIVES**

6.30

USED WITHINS

REMOVAL

1. Open the engine compartment and fit paintwork protection sheets.
2. Set the engine compartment cover to the service access position.

3.

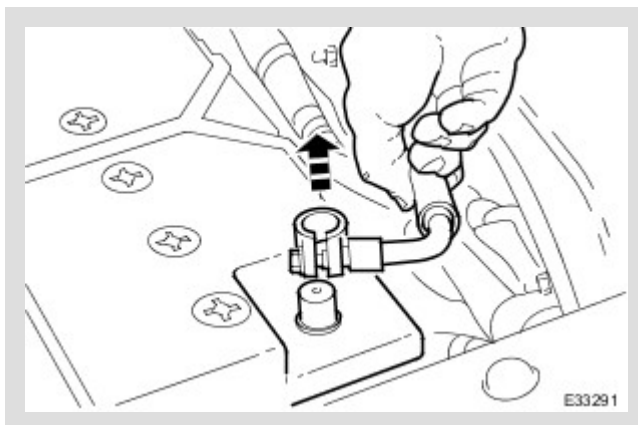

Disconnect the battery ground cable.

Remove the battery cover.

4. Remove the Timing Cover. Refer to Operation 12.65.01 in this Section.

5. Remove the VVT Unit from the A-Bank. Refer to Operation 12.65.70 in this Section. This also includes the VVT Bush Carrier Assembly, Primary Chain and Tensioner.

6. Remove the camshaft locking tool JD 215 (fitted for previous operation).

7.

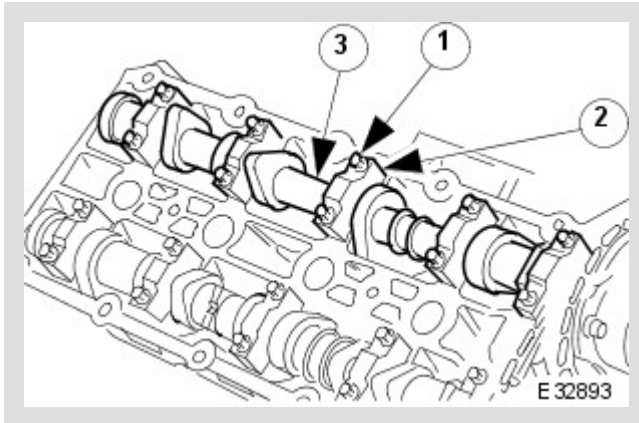

Remove the camshaft.

1. Remove the bolts which secure the camshaft caps; loosen them evenly, in stages.
2. Remove the camshaft caps. Note their orientation and markings - each is marked with its position (a number) and orientation (an arrow).
3. Remove the camshaft from the engine.

8. Clean and inspect all relevant components.

INSTALLATION

1.

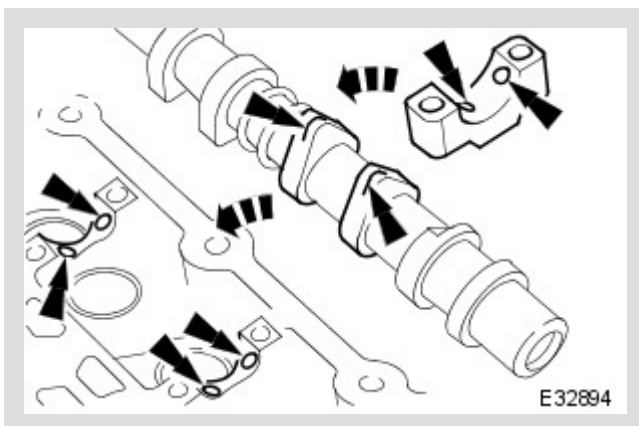

Apply oil (EP-90) to the camshaft and bearing surfaces, as follows:

To the upper face of each bearing surface (two places) in the cylinder head.

To the upper face of each bearing surface (two places) in each bearing cap.

On the cam lobes ONLY, not on the base circle area.

2.

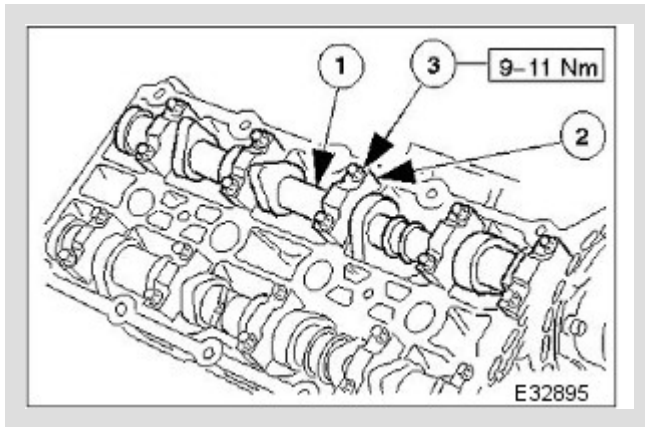

Refit the camshaft.

1. Fit the camshaft to position in the cylinder head, with the timing flats uppermost.
2. Fit the camshaft caps to their respective locations (0 to 4 from the front) and in the correct orientation (arrow to front of engine).
3. Fit and tighten the cap securing bolts. Tighten evenly, in stages, to 9-11 Nm.

3. Fit the camshaft locking tool JD 215 (fitted for following operation) align the camshaft as necessary.

4. Refit the VVT Unit to the A-Bank. Refer to Operation 12.65.70 in this Section. This also includes the VVT Bush Carrier Assembly, Primary Chain and Tensioner.

5. With the camshaft (JD 215) and crankshaft (JD 216) setting tools removed, after the previous operation, adjust the valve clearances on the inlet camshaft. refer to Operation 12.29.48 in this Section.

6. Refit the Timing Cover. Refer to Operation 12.65.01 in this Section.

7. Move the engine compartment cover from the service position and connect the gas struts.

8. Remove the paint protection sheets and close the cover.

9. Connect the battery and fit the battery cover.

Refer to the Battery Reconnection Procedure 86.15.15.