

ENGINE

VARIABLE CAMSHAFT TIMING OIL CONTROL
UNIT HOUSING LH [G222826]

IN-VEHICLE REPAIR

12.65.52	VARIABLE VALVE TIMING BUSHING CARRIER ASSEMBLY - BANK 2 - RENEW	ALL DERIVATIVES	4.50	USED WITHINS	
----------	--	--------------------	------	--------------	--

12.65.52	VARIABLE VALVE TIMING BUSHING CARRIER ASSEMBLY - BANK 2 - RENEW	ALL DERIVATIVES	4.50	USED WITHINS	
----------	--	--------------------	------	--------------	--

REMOVAL

1. Open the engine compartment and fit paintwork protection sheets.

2. Set the engine compartment cover to the service access position.

3.

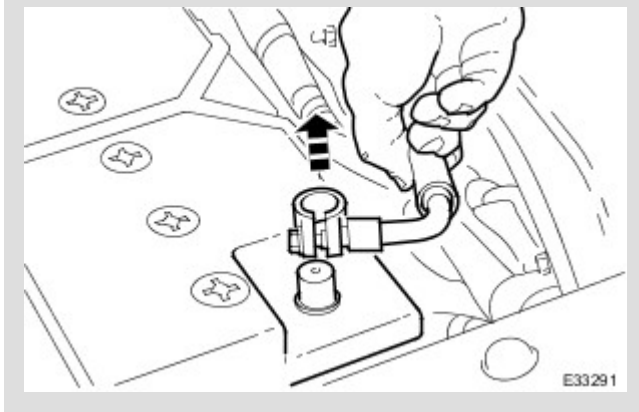

Disconnect the battery ground cable.

Remove the battery cover.

4. Remove the Timing Cover. Refer to Operation 12.65.01 in this Section.

5.

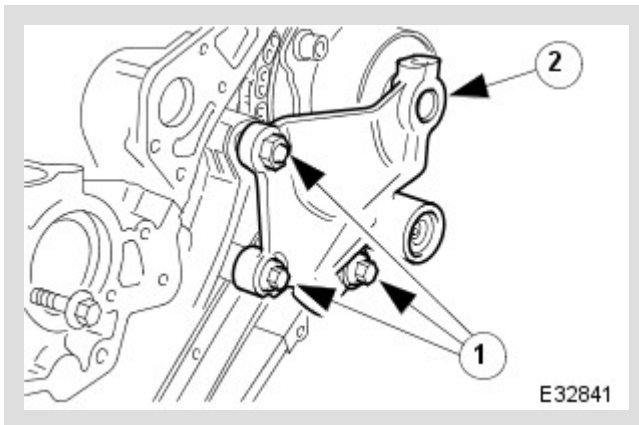

Remove the VVT bush carrier.

1. Remove the two bolts and one nut which secure the carrier to the cylinder block.

2. Release the carrier from the two ring dowels and remove it.

6.

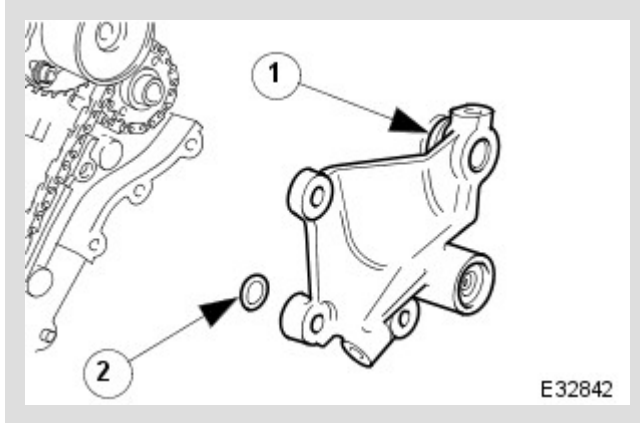

Remove the seals from the bush carrier.

1. Remove the sealing ring (scarf jointed) from the carrier bush groove.
2. Remove the O-ring from the carrier oil-way recess.

7. Clean and inspect all relevant components.

INSTALLATION

1.

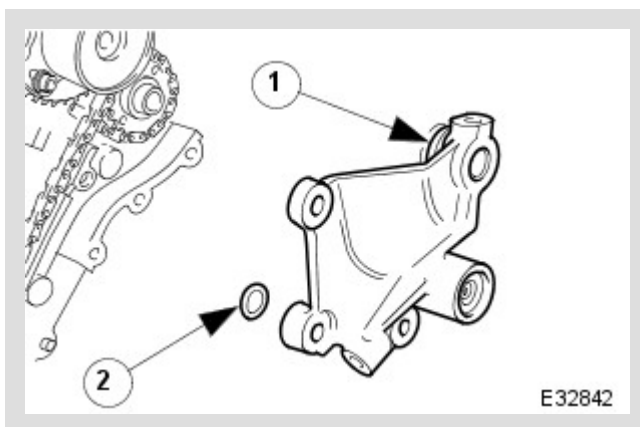

Fit new seals to the bush carrier.

1. Fit the new sealing ring (scarf jointed) to the carrier bush groove.
2. Fit a new O-ring to the carrier oil-way.

2.

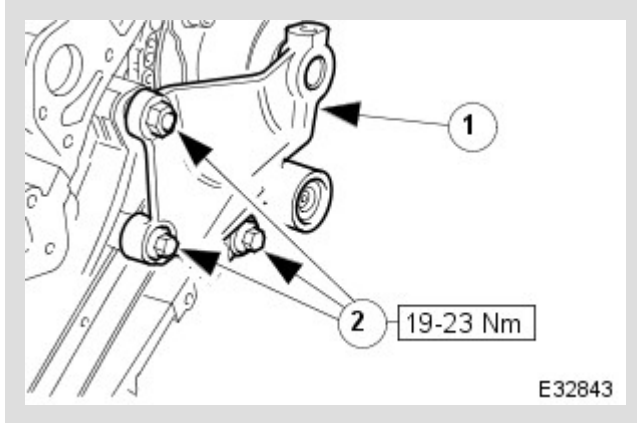

Fit the bush carrier to the cylinder block.

Lubricate the seal (scarf jointed) and the bush.

1. Fit the bush carrier assembly.

Check that the seals are in place and that the ring dowels are engaged squarely. Fully locate the assembly as much as possible by hand pressure.

2. Fit the two securing bolts and one nut. Tighten to 19-23 Nm.

-
3. Refit the Timing Cover. Refer to Operation 12.65.01 in this Section.

-
4. Move the engine compartment cover from the service position and connect the gas struts.

-
5. Remove the paint protection sheets and close the cover.

-
6. Connect the battery and fit the battery cover.

Refer to the Battery Reconnection Procedure 86.15.15.