

ENGINE

PRIMARY TIMING CHAIN OUTER GUIDE LH

[G222809]

IN-VEHICLE REPAIR

12.65.61	TIMING CHAIN GUIDE - PRIMARY - BANK 2 - RENEW	ALL DERIVATIVES	4.70	USED WITHINS
----------	--	----------------------------	-------------	---------------------

12.65.61	TIMING CHAIN GUIDE - PRIMARY - BANK 2 - RENEW	ALL DERIVATIVES	4.70	USED WITHINS
----------	--	----------------------------	-------------	---------------------

REMOVAL

1. Open the engine compartment and fit paintwork protection sheets.

2. Set the engine compartment cover to the service access position.

3.

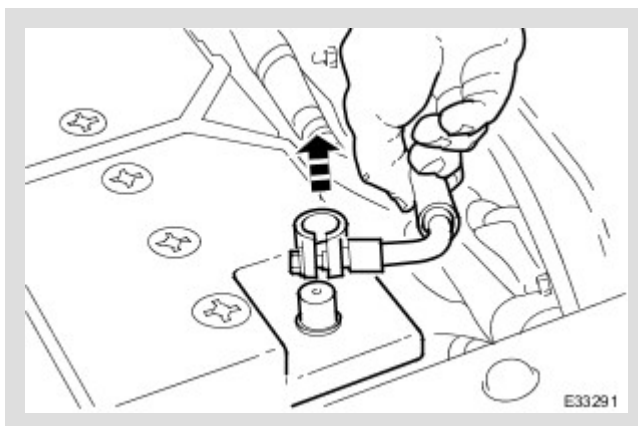

Disconnect the battery ground cable.

Remove the battery cover.

4. Remove the Timing Cover. Refer to Operation 12.65.01 in this Section.

5. Remove the VVT Bush Carrier Assembly from the B-Bank. Refer to Operation 12.65.52 in this Section.

6. Remove the Timing Chain Tensioner - Primary, from the B-Bank. Refer to Operation 12.65.55 in this Section.

7.

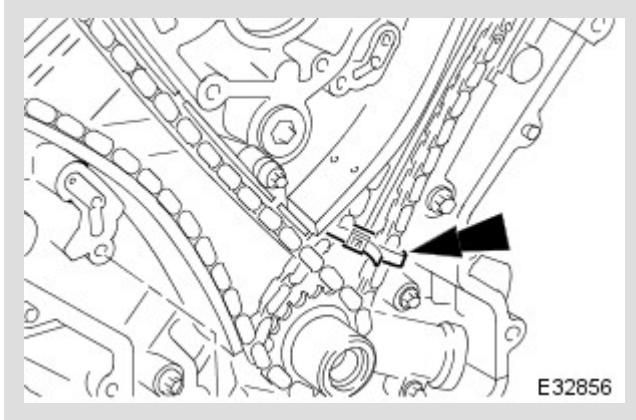

Fit a Tie-Strap through the links of the primary chain, just above the crankshaft sprocket, to retain the chain to the sprocket.

8.

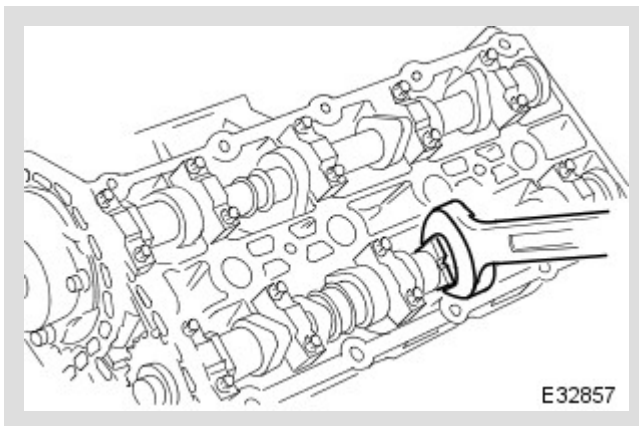

Rotate the inlet camshaft (and the exhaust camshaft), using a spanner on the flats, to provide sufficient slack in the chain to remove the chain guide.

9.

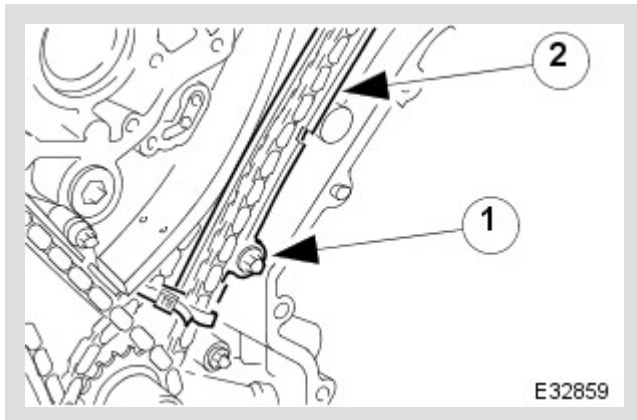

Remove the chain guide.

1. Remove the bolt which secures the chain guide.
2. Note the orientation of the chain guide and remove it from the upper retaining pin.

10. Clean and inspect all relevant components.

INSTALLATION

1.

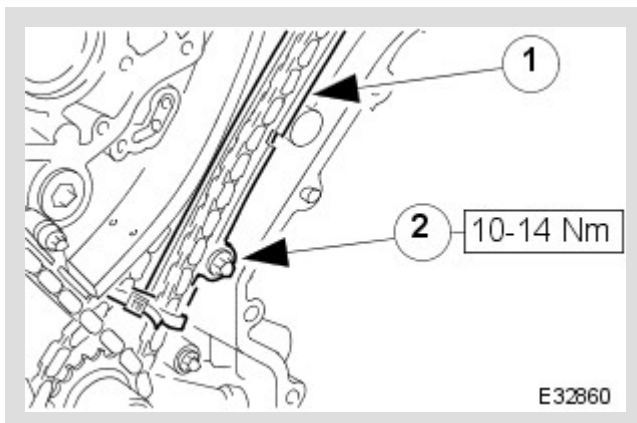

Fit the chain guide.

The chain guide must be fitted so that the slotted hole is towards the top, and the raised shoulder to the cylinder block.

1. Fit the chain guide to the block and locate it onto the upper retaining pin.
2. Fit the retaining bolt and tighten it to 10-14 Nm.

2. Remove the Tie-Strap from the chain.

3. Refit the Timing Chain Tensioner - Primary. The camshafts may need to be turned slightly to provide slack in the chain, on the tensioner side. Refer to Operation 12.65.55 in this Section.

4. Refit the VVT Bush Carrier Assembly. Refer to Operation 12.65.52 in this Section.

5. Refit the Timing Cover. Refer to Operation 12.65.01 in this Section.

6. Move the engine compartment cover from the service position and connect the gas struts.

7. Remove the paint protection sheets and close the cover.

8. Connect the battery and fit the battery cover.

Refer to the Battery Reconnection Procedure 86.15.15.

bmdyZWdzbzE7MjAyMCOwNC0yOF0xND0zND0zOS43NTVaOzg2LjE3MyfyMDcuMjQzOw==