

ENGINE

EXHAUST CAMSHAFT SPROCKET LH [G222797]

IN-VEHICLE REPAIR

12.65.74	EXHAUST CAMSHAFT SPROCKET - BANK 2 - RENEW	ALL DERIVATIVES	1.60	USED WITHINS
12.65.74	EXHAUST CAMSHAFT SPROCKET - BANK 2 - RENEW	ALL DERIVATIVES	1.60	USED WITHINS

SPECIAL TOOL(S)

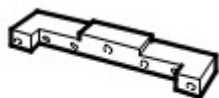

E36401

303-530

Camshaft setting



E36408

303-531

Crankshaft setting



E36402

303-532

Timing chain tensioning

REMOVAL

1. Open the engine compartment and fit paintwork protection sheets.
2. Set the engine compartment cover to the service access position.

-
3. Open the driver's door, or both doors if necessary, to allow the side glass to drop. Make sure that the doors remain open until after the battery has been disconnected.
-

4.

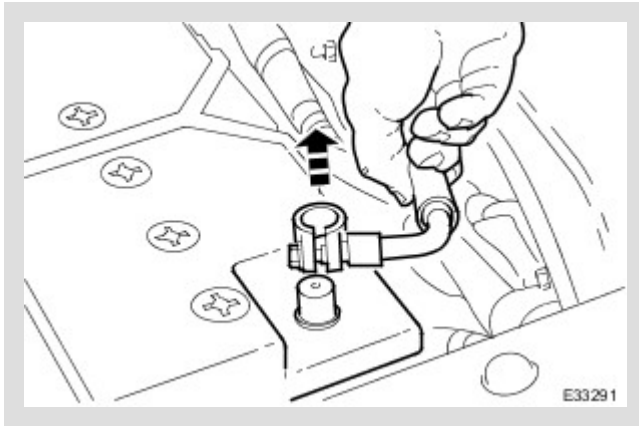

Disconnect the battery ground cable.

Remove the battery cover.

5. Remove the RH valve cover. For additional information, refer to: [Right Valve Cover](#) (303-01 Engine, In-vehicle Repair).
-

6. Raise the vehicle on a ramp.
-

7.

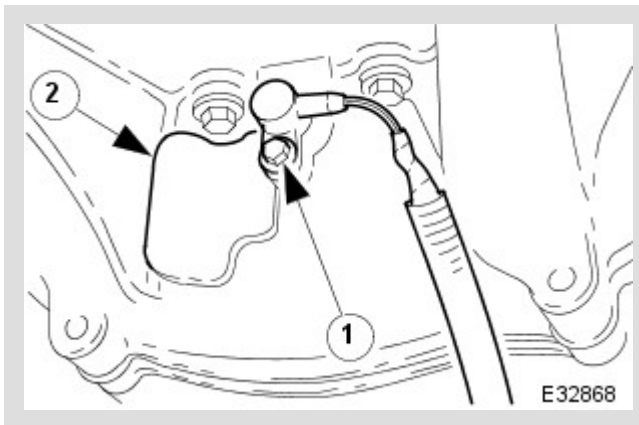

Remove the crankshaft position sensor.

1. Remove the bolt which secures the crankshaft position sensor to the flywheel housing.

Remove the sensor and allow it to hang free under the engine.

2. Remove the access grommet (for torque converter bolts) from the housing.
-

8.

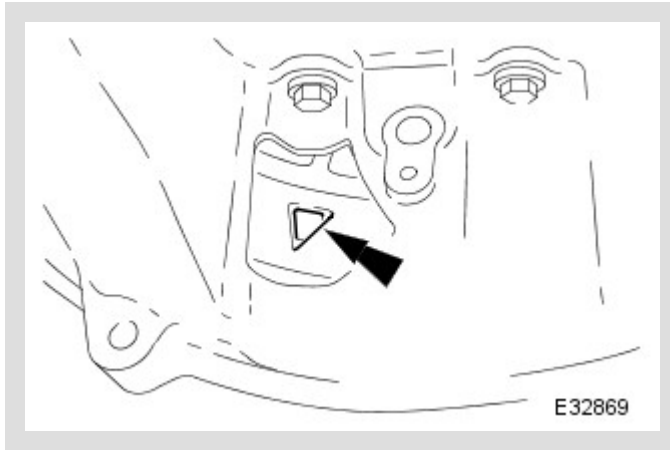

Rotate the crankshaft until the triangular arrow indent on the drive plate is visible through the access hole; confirm that the timing flat on each camshaft is uppermost.

9.

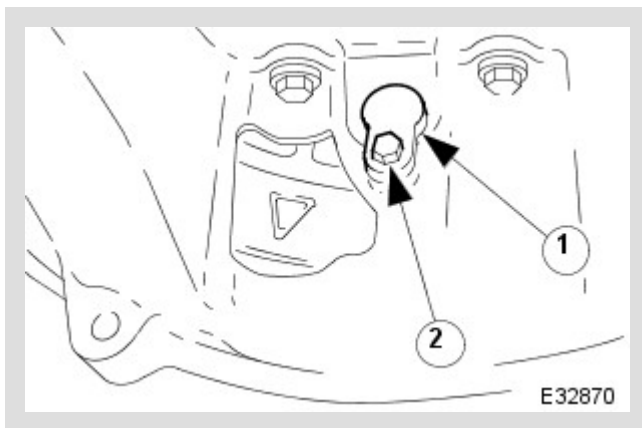

Install the crankshaft setting peg 303-531 to the crankshaft position sensor location.

1. Install the crankshaft setting peg 303-531.

Position the crankshaft so that the setting peg engages fully into the timing slot.

2. Install and tighten the bolt to secure the setting peg.

10. Lower the vehicle on the ramp.

11.

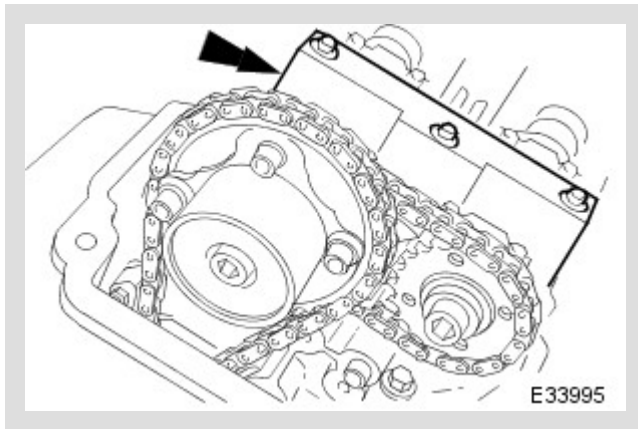

Install the camshaft locking tool 303-530 to LH camshafts, aligning the shafts slightly as necessary.

12.

⚠ CAUTION:

Use a length of steel strip that will not fall into the timing cover.

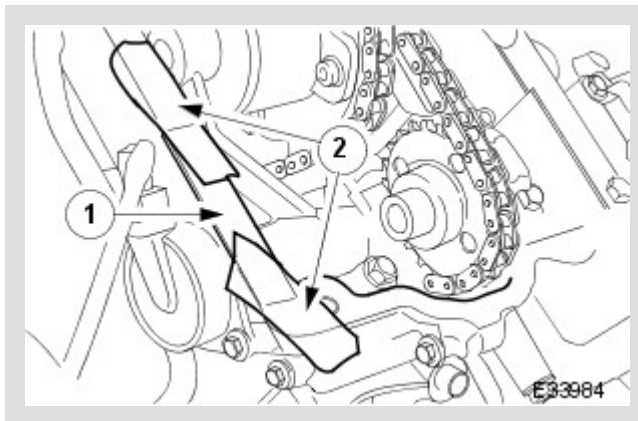

Protect the upper face of the timing cover from scratches, when removing the bolt which secures the sprocket.

1. Place a flat piece of steel strip along the timing cover horizontal jointing face, adjacent to the exhaust camshaft sprocket.
2. Secure the steel strip in place with adhesive tape.

13.



A ball-ended hexagon drive bit is required to remove the sprocket securing bolt. A suitable tool is available from Snap On as (FABLM10E) Long Series 10mm AF.

14.

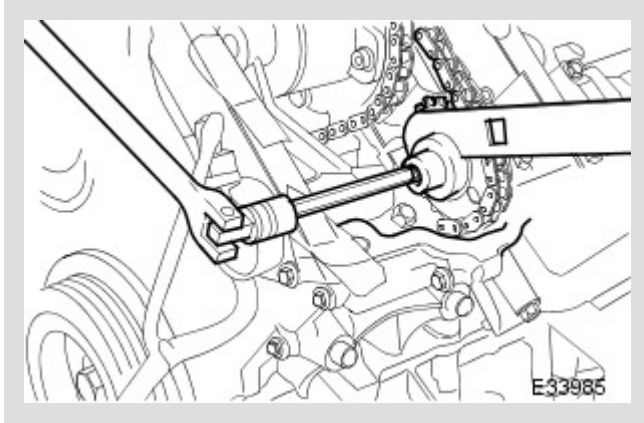

Remove the bolt which secures the sprocket to the exhaust camshaft.

Move the sprocket forward from the camshaft boss.

Remove the sprocket and leave the chain resting on the cylinder head.

15. Clean and inspect all relevant components.

INSTALLATION

1.

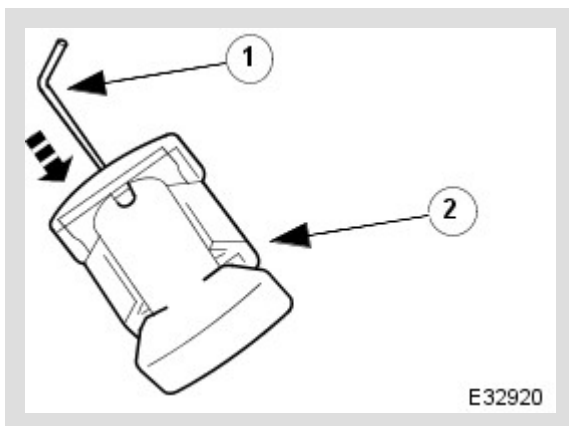

Push the tensioner piston into the body to provide clearance for installing. Tensioner fitted to cylinder head.

1. Insert a thin rigid wire through the hole in the end of the tensioner piston to displace the ball from the non-return valve seat.
2. With the wire in position, press the piston fully into the tensioner body.

Remove the wire.

2.

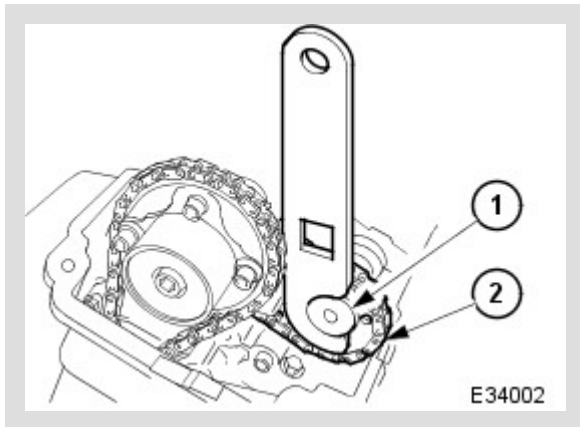

Install the sprocket to the secondary chain.

1. With the sprocket installed to the chain, temporarily position the sprocket onto the camshaft.
2. Adjust the position of the sprocket within the chain to allow the chain tensioning tool 303-532 to be approximately vertical, as shown.

3.

⚠ CAUTION:

Make sure that a new bolt is installed.

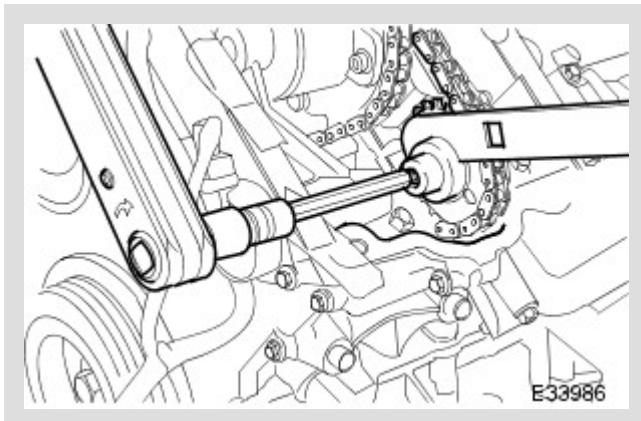

Install the camshaft sprocket.

Install the bolt to secure the sprocket.

Apply force to the tool (303-532) in an anti-clockwise direction to tension the chain on its drive side.

Whilst applying the opposing force to the sprocket and chain, tighten the sprocket securing bolt to 20 Nm + 90°.

Remove the chain tensioning tool.

4. Remove the tape and steel strip from the timing cover upper face. Wipe any residue of tape from the joint face.

5. Remove the camshaft locking tool.

6. Install the RH valve cover. For additional information, refer to: [Valve Cover Gasket RH](#) (303-01 Engine, In-vehicle Repair).

7. Raise the vehicle on the ramp.

8. Remove the crankshaft setting tool 303-531.

9.

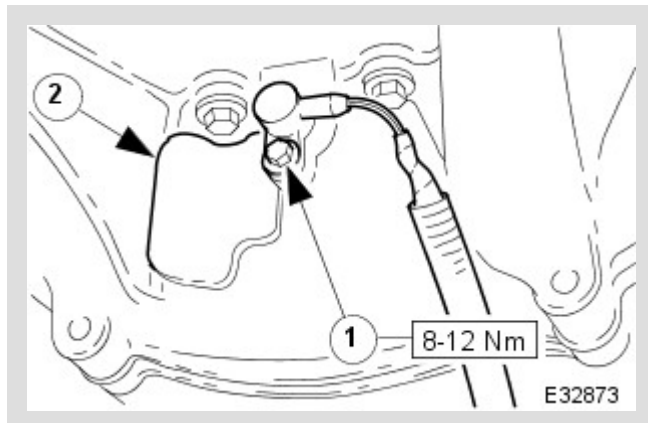

Install the crankshaft position sensor.

1. Install the sensor to the flywheel housing and fit the securing bolt. Tighten to 10 Nm.
2. Install the access grommet to the housing.

10. Lower the ramp.

11. Move the engine compartment cover from the service position and connect the gas struts.

12. Remove the paint protection sheets and close the engine compartment cover.

13. Connect the battery and install the battery cover. For additional information, refer to: [Battery Connect](#) (414-01 Battery, Mounting and Cables, General Procedures).

PUBLISHED: 11-MAY-2011
1997.0 X100, 303-01

ENGINE

VALVE COVER GASKET RH [G222821]

IN-VEHICLE REPAIR

12.29.41	CAMSHAFT COVER GASKET - EACH - RENEW	ALL DERIVATIVES	1.10	USED WITHINS
-----------------	---	----------------------------	-------------	---------------------

12.29.41	CAMSHAFT COVER GASKET - EACH - RENEW	ALL DERIVATIVES	1.10	USED WITHINS
-----------------	---	----------------------------	-------------	---------------------

12.29.41	CAMSHAFT COVER GASKET - EACH - RENEW	ALL DERIVATIVES	1.10	USED WITHINS
-----------------	---	----------------------------	-------------	---------------------

REMOVAL

1. Open the engine compartment and fit paintwork protection sheets.
2. Carefully remove the right hand engine cover, taking care not to damage the plastic fixings or the rubber inserts.
3. Remove the on-plug ignition coils from the 'A' bank. Refer to Operation 18.20.41.

4.

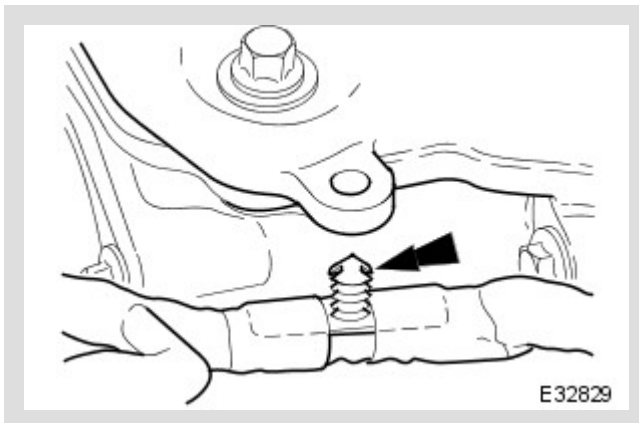

Release the four clips which secure the engine harness to the cam cover.

5.

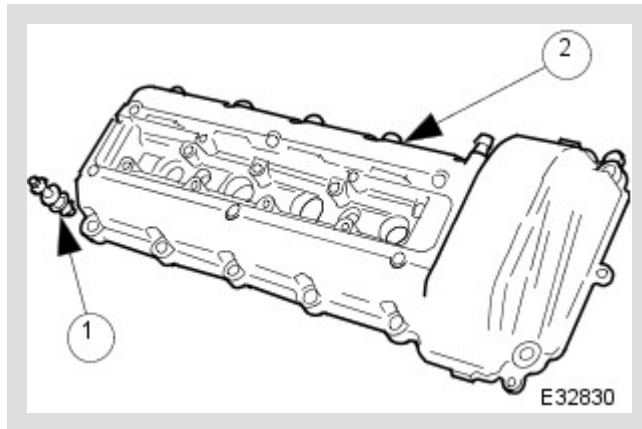

Remove the cam cover assembly.

1. Release the fourteen screws which secure the cam cover. The screws stay in place, held by the seals.
2. Remove the cam cover, screws and seals, as an assembly.

6.

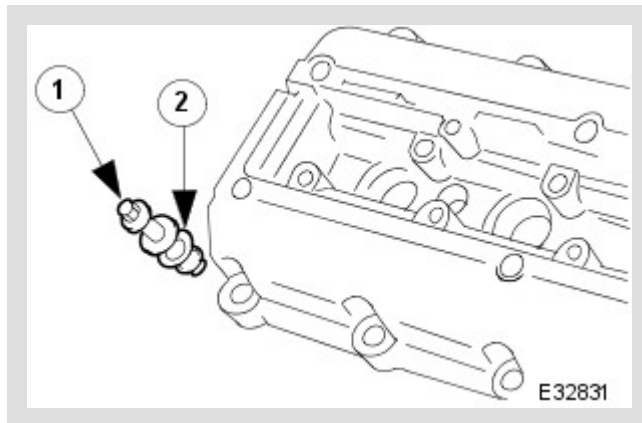

Separate the screws and seals from the cam cover.

1. One at a time, remove each securing screw from the cam cover.
2. Remove the rubber sealing ring from each securing screw.

7.

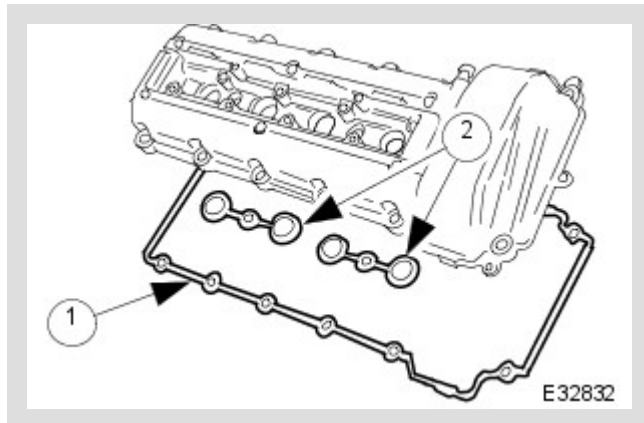

Remove the main seals from the cam cover.

1. Remove and discard the outer seal.
2. Remove and discard the two seals from around the spark plug apertures.

8. Clean all relevant parts and mating faces.

INSTALLATION

1.

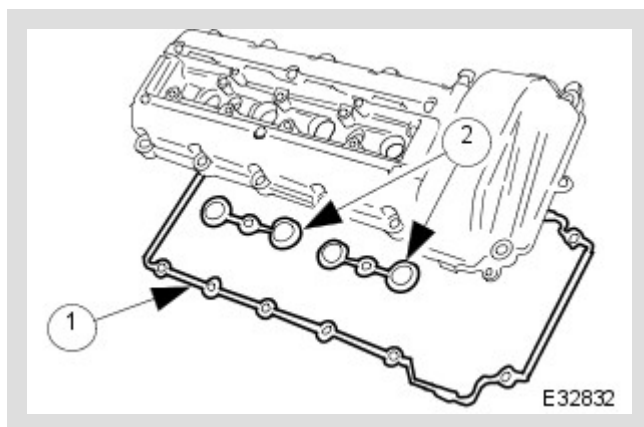

Fit the new main seals to the cam cover.

1. Fit the new outer seal.
2. Fit the two new spark plug aperture seals.

2.

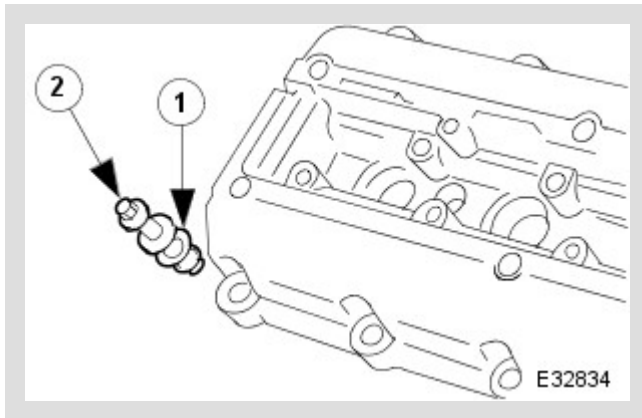

Fit the securing screws to the cam covers.

1. Fit a new sealing ring to each screw assembly.
2. Fit the screws to the cam covers. Each screw is retained by the cam cover gasket.

3.

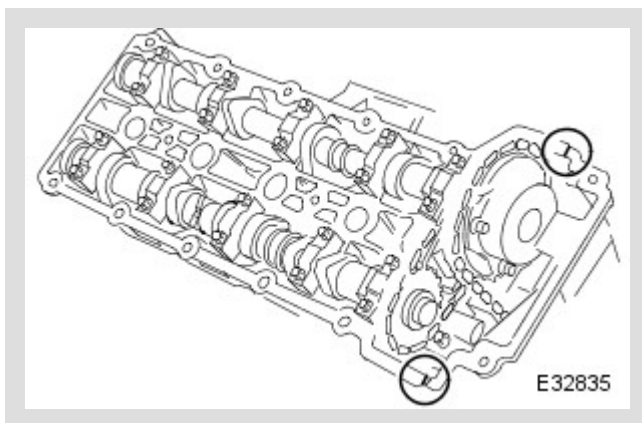

Apply sealant to two places on the joint between the front of the cam cover and the cylinder head.

The application of sealant must be 3mm diameter by 12mm long. Fit the cam cover immediately after applying the sealant.

The cover should be fitted directly to the head without smearing the sealant or the seals.

4.

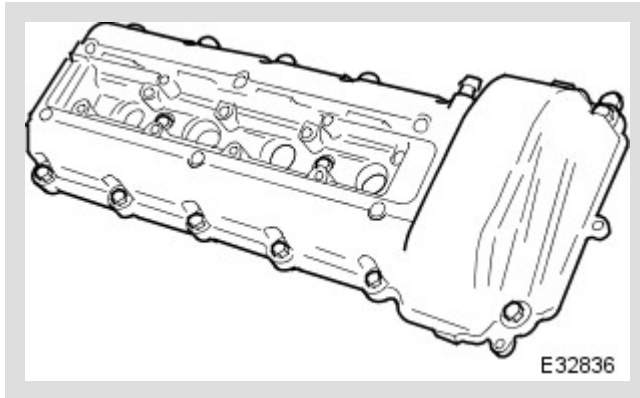

Refit the cam cover.

1. Position the cam cover onto the cylinder head without smearing the sealant and start the threads of each securing screw.

5.

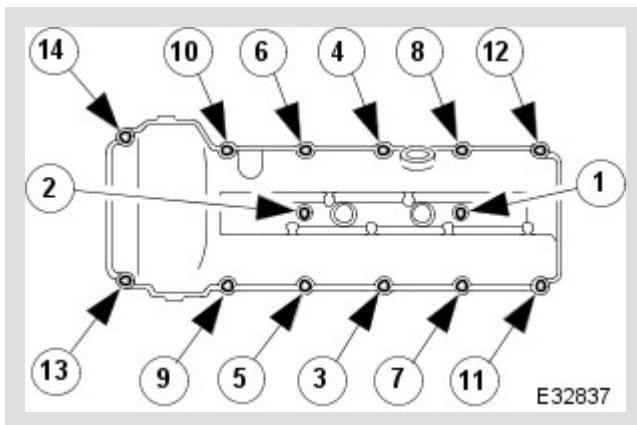

Tighten the securing screws to 9-11 Nm. Tighten in the sequence indicated.

6.

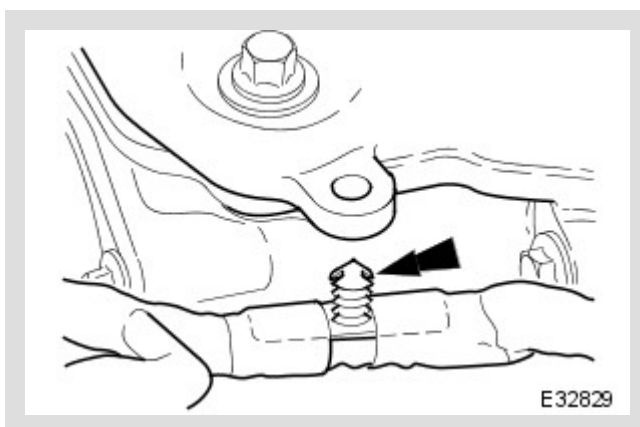

Reposition the clips which secure the engine harness to the cam cover.

7. Refit the on-plug ignition coils and the coil cover. Refer to Operation 18.20.41.

8. Refit the right hand engine cover.

-
9. Remove the paintwork protection sheets and close the engine compartment.

PUBLISHED: 11-MAY-2011
1997.0 X100, 414-01

BATTERY, MOUNTING AND CABLES

BATTERY CONNECT [G222938]

GENERAL PROCEDURES

1.  **NOTE:**

Whether one, or both, cables are disconnected, a minimum of 30 seconds **MUST** elapse between disconnection of the **FIRST** cable and reconnection of the **LAST** cable. A clean final connection must be made; do not allow temporary contact.

Connect the battery terminal(s).

-
2. Reset the clock.

-
3. Enter the radio security code. If necessary, refer to the Sound System Handbook.

-
4. Cycle (both) door drop glass up and down to establish the upper and lower datum points.

Switch the ignition ON .

Lower the glass to the stop and hold the switch in the DOWN position for a further five seconds.

Raise the glass fully and hold the switch in the UP position for a further five seconds.

-
5. Switch the ignition OFF .

PUBLISHED: 11-MAY-2011
1997.0 X100, 303-01

ENGINE

RIGHT VALVE COVER [G222819]

IN-VEHICLE REPAIR

12.29.44	CAMSHAFT COVER - EACH - RENEW	ALL DERIVATIVES	1.10	USED WITHINS
----------	--	--------------------	------	--------------

12.29.44	CAMSHAFT COVER - EACH - RENEW	ALL DERIVATIVES	1.10	USED WITHINS
----------	--	--------------------	------	--------------

12.29.44	CAMSHAFT COVER - EACH - RENEW	ALL DERIVATIVES	1.10	USED WITHINS
----------	--	--------------------	------	--------------

REMOVAL

1. Open the engine compartment and fit paintwork protection sheets.

2.

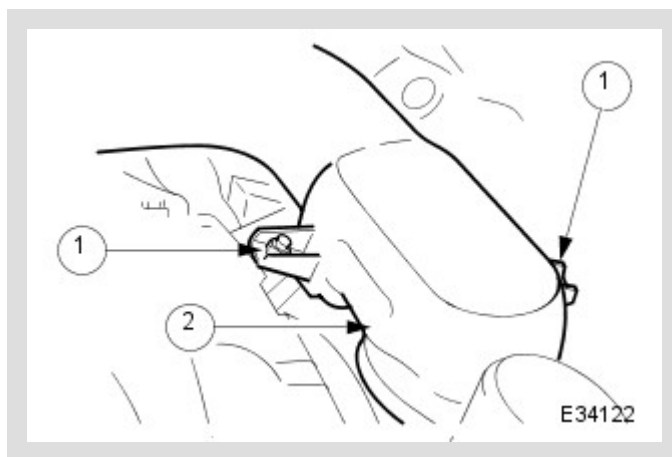

Disconnect the intake tube from the throttle body.

1. Remove the two bolts which secure the intake tube to the throttle body.
2. Disconnect the intake tube from the throttle body.

3.

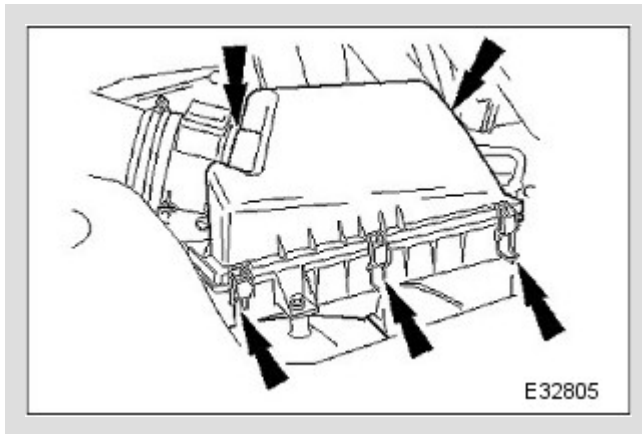

Disconnect the air cleaner cover.

Release the five clips which secure the air cleaner cover.

4.

Disconnect the air flow meter multi-plug.

5.

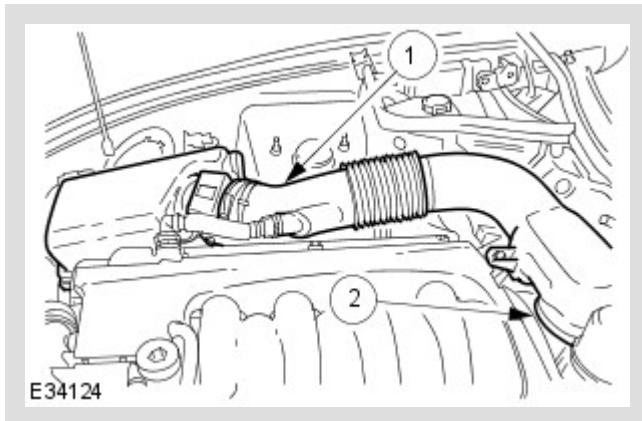

Remove the intake tube / air flow meter / air cleaner cover assembly.

1. Remove the intake tube / air flow meter / air cleaner cover assembly.

2. Remove and discard the rubber seal; air intake tube to throttle body.

6.

Carefully remove the right hand engine cover, taking care not to damage the plastic fixings or the rubber inserts.

7.

Remove the on-plug ignition coils from the 'A' bank. Refer to Operation 18.20.41.

8.

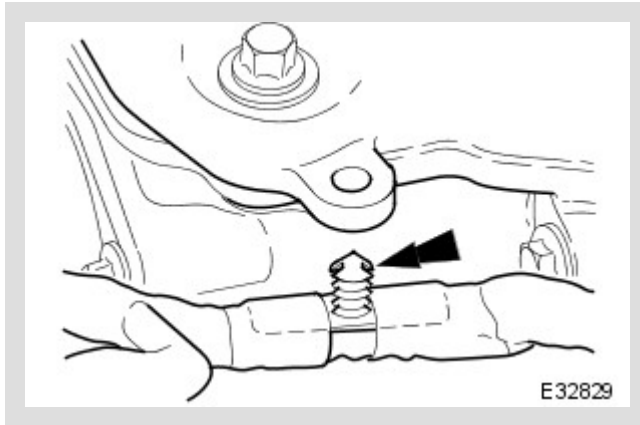

Release the clips which secure the engine harness to the cam cover.

9.

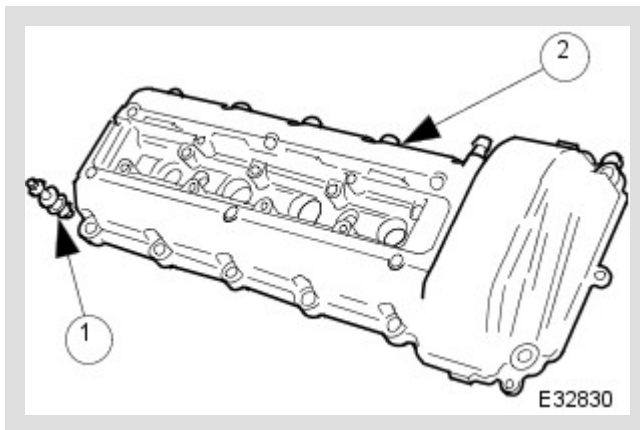

Remove the cam cover assembly.

1. Release the fourteen screws which secure the cam cover. The screws stay in place, held by the seals.
2. Remove the cam cover, screws and seals, as an assembly.

10.

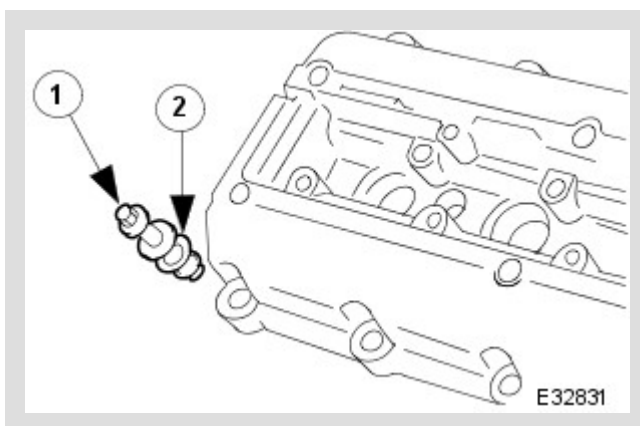

Separate the screws and seals from the cam cover.

1. One at a time, remove each securing screw from the cam cover.
2. Remove the rubber sealing ring from each securing screw.

11.

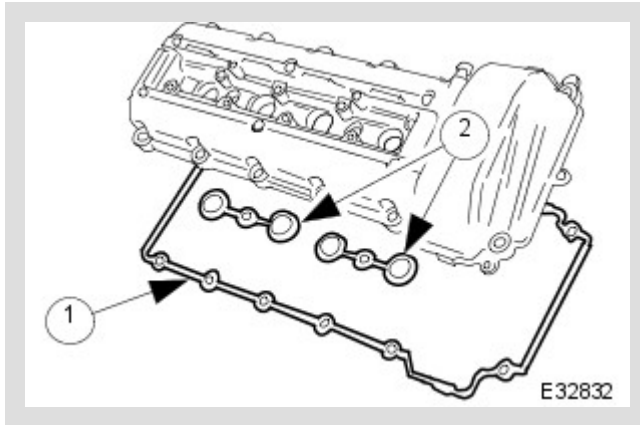

Remove the main seals from the cam cover.

1. Remove and discard the outer seal.
2. Remove and discard the two seals from around the spark plug apertures.

12. Clean all relevant parts and mating faces.

INSTALLATION

1.

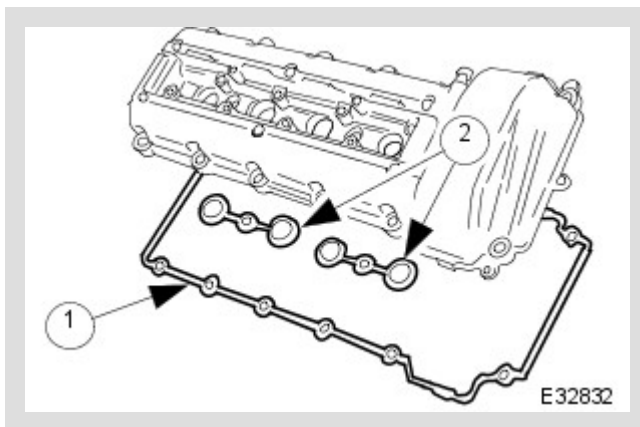

Fit the new main seals to the cam cover.

1. Fit the new outer seal.
2. Fit the two new spark plug aperture seals.

2.

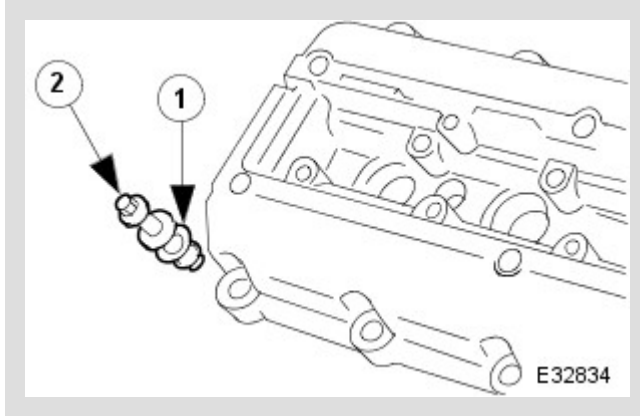

Fit the securing screws to the cam covers.

1. Fit a new sealing ring to each screw assembly.
2. Fit the screws to the cam covers. Each screw is retained by the cam cover gasket.

3.

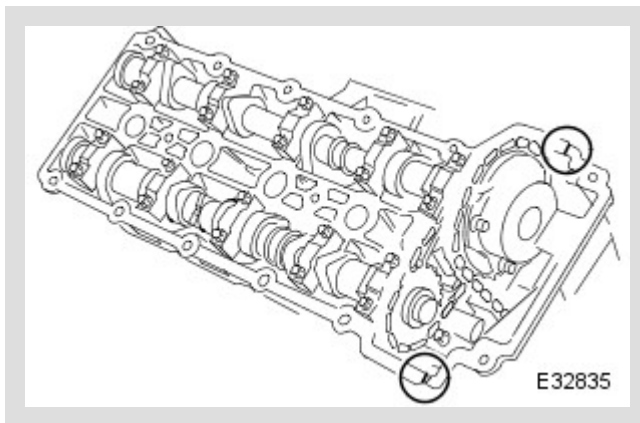

Apply RTV sealant WSS-M4G320-A3 to two places on the joint between the front of the cam cover and the cylinder head.

The application of sealant must be 3mm diameter by 12mm long. Fit the cam cover immediately after applying the sealant.

The cover should be fitted directly to the head without smearing the sealant or the seals.

4.

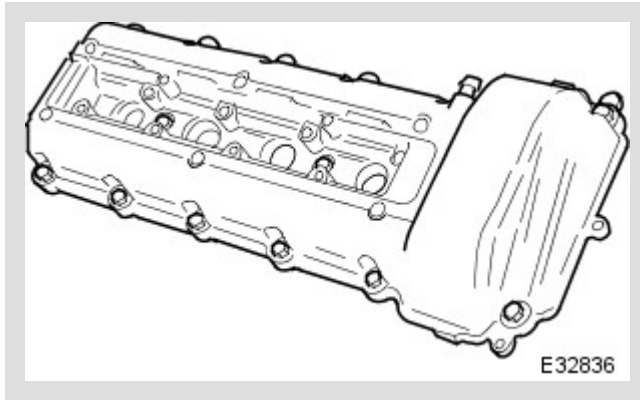

Refit the cam cover.

Position the cam cover onto the cylinder head without smearing the sealant and start the threads of each securing screw.

5.

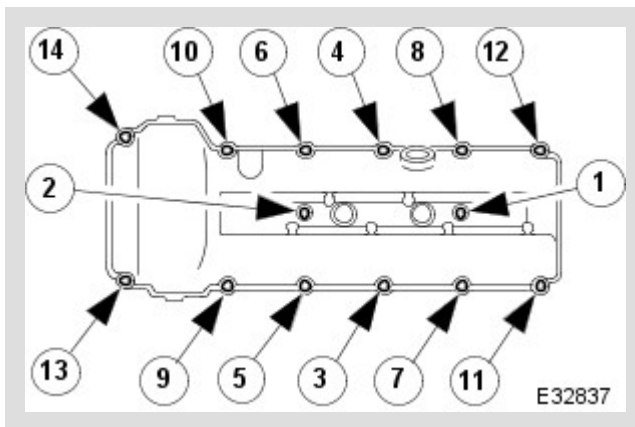

Tighten the securing screws to 9-11 Nm. Tighten in the sequence indicated.

6.

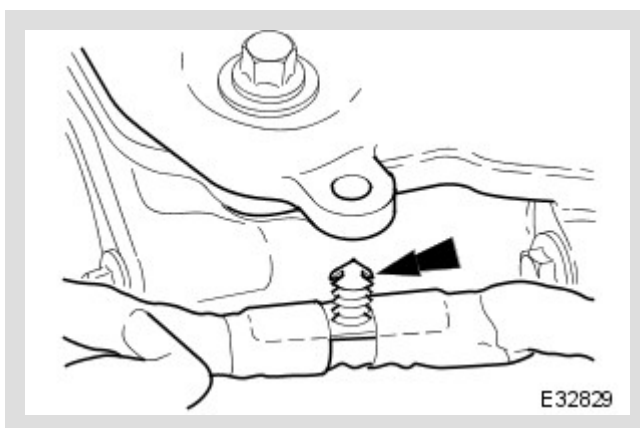

Reposition the clips which secure the engine harness to the cam cover.

7. Refit the on-plug ignition coils and the coil cover. Refer to Operation 18.20.41.

8. Refit the right hand engine cover.

9.

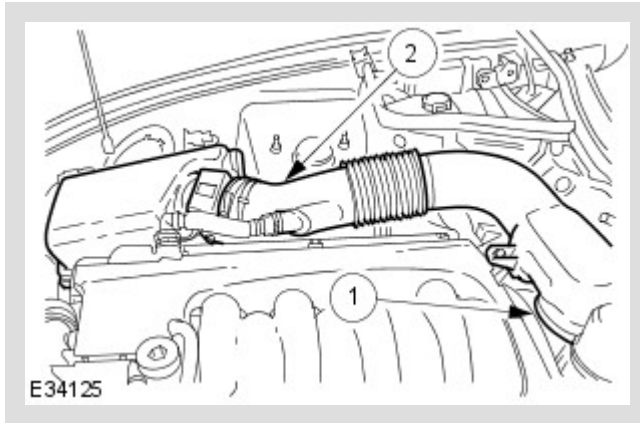

Fit the intake tube / air flow meter / air cleaner cover assembly.

1. Fit a new rubber seal; air intake tube to throttle body.
2. Fit the intake tube / air flow meter / air cleaner cover assembly.

10.

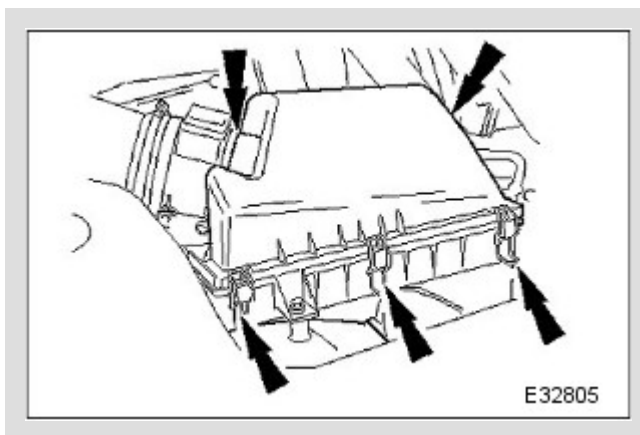

Reconnect the air cleaner cover.

Fit the five clips which secure the air cleaner cover.

11.

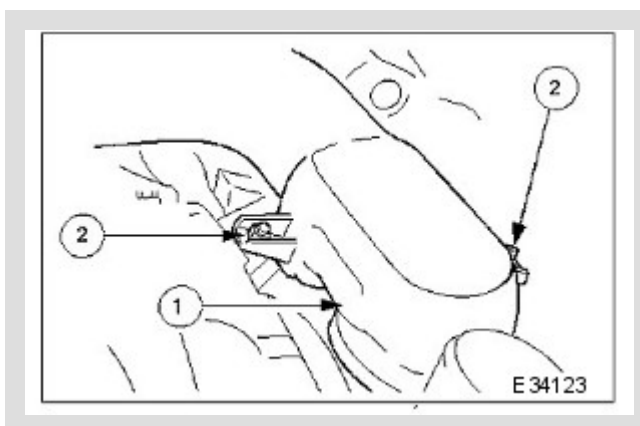

Connect the intake tube to the throttle body.

1. Connect the intake tube to the throttle body.
2. Fit the two bolts which secure the intake tube to the throttle body.

12. Remove the paintwork protection sheets and close the engine compartment.