

ENGINE

# VARIABLE CAMSHAFT TIMING OIL CONTROL UNIT LH [G222824]

**IN-VEHICLE REPAIR**

<b>12.65.71</b>	<b>VARIABLE VALVE TIMING UNIT - BANK 2 - RENEW</b>	<b>ALL DERIVATIVES</b>	<b>5.10</b>	<b>USED WITHINS</b>	
-----------------	--	----------------------------	-------------	---------------------	--

<b>12.65.71</b>	<b>VARIABLE VALVE TIMING UNIT - BANK 2 - RENEW</b>	<b>ALL DERIVATIVES</b>	<b>5.00</b>	<b>USED WITHINS</b>	
-----------------	--	----------------------------	-------------	---------------------	--

**SPECIAL TOOL(S)**

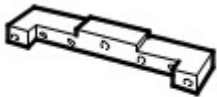

E36401

**JD 215**

Camshaft setting



E36402

### **JD 217**

Timing chain tensioning



E36407

### **JD 218**

Wedges, primary chain



E36408

## JD 216

Crankshaft setting

### REMOVAL

1. Open the engine compartment and install paintwork protection sheets.

2. Set the engine compartment cover to the service access position.

3.

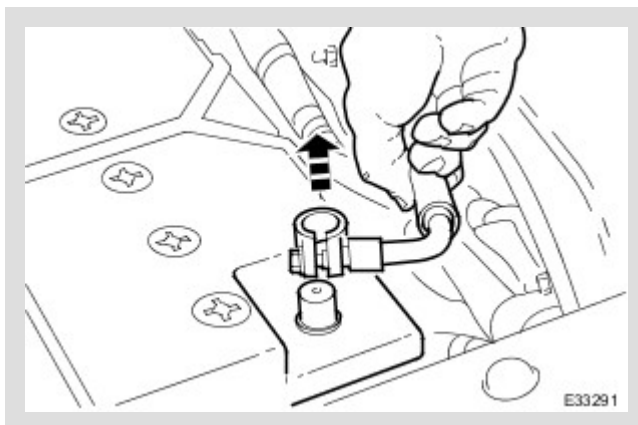

Disconnect the battery ground cable.

Remove the battery cover.

4. Remove the engine front cover. For additional information, refer to: [Engine Front Cover](#) (303-01 Engine, In-vehicle Repair).

5. Remove the LH variable valve camshaft timing oil control unit housing. For additional information, refer to: [Variable Camshaft Timing Oil Control Unit Housing LH](#) (303-01 Engine, In-vehicle Repair).

6. Raise the vehicle on a ramp.

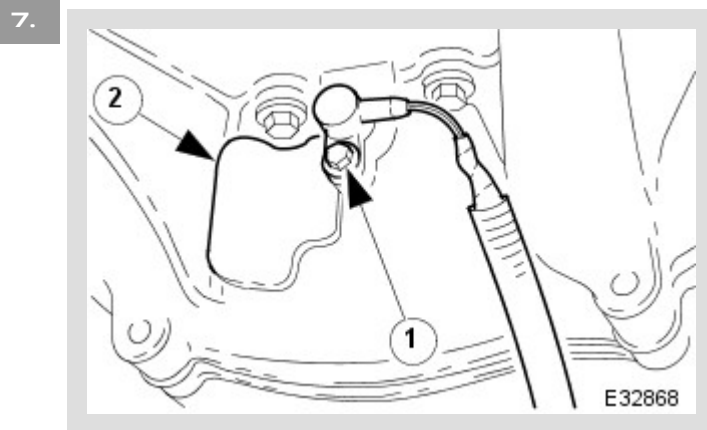

Remove the crankshaft position sensor.

1. Remove the bolt which secures the crankshaft position sensor to the flywheel housing.

Remove the sensor and allow it to hang free under the engine.

2. Remove the access grommet (for torque converter bolts) from the housing.

8. Install the damper securing bolt (old one) to the crankshaft, hand-tight only.

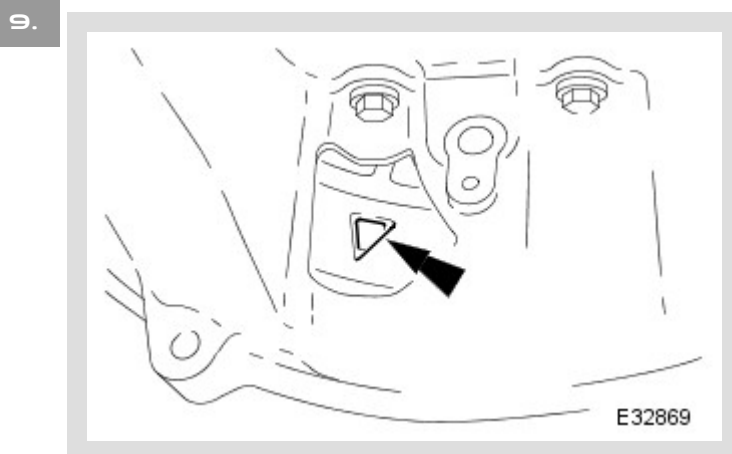

Rotate the crankshaft until the triangular arrow indent on the drive plate is visible through the access hole; confirm that the timing flat on each camshaft is uppermost.

10.

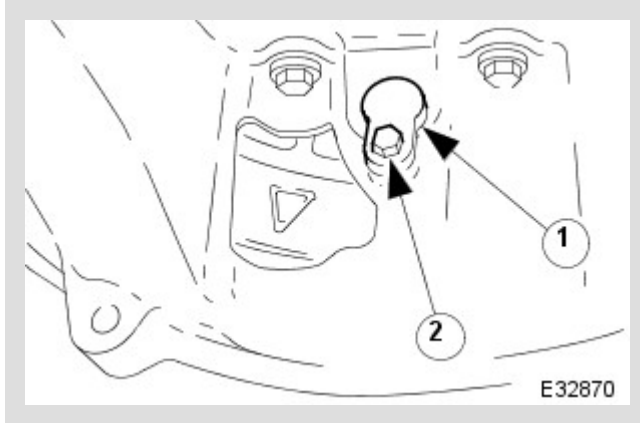

Install the crankshaft setting peg JD 216 to the crankshaft position sensor location.

1. Install the crankshaft setting peg JD 216.

Position the crankshaft so that the setting peg engages fully into the timing slot.

2. Install and tighten the bolt to secure the setting peg.

11. Remove the damper securing bolt from the crankshaft.

12. Lower the vehicle on the ramp.

13.

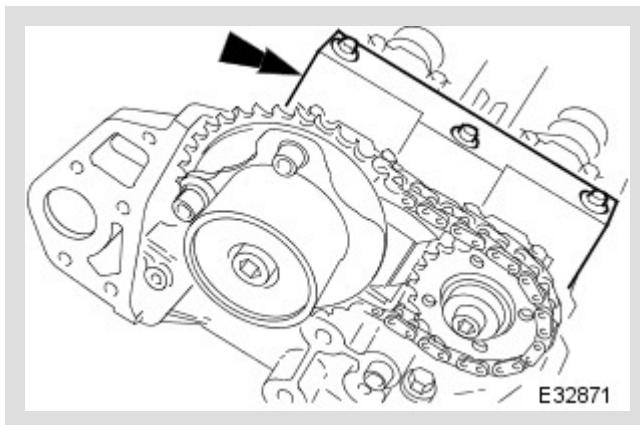

Install the camshaft locking tool JD 215 to the B-Bank camshafts, aligning the shafts slightly as necessary.

14.

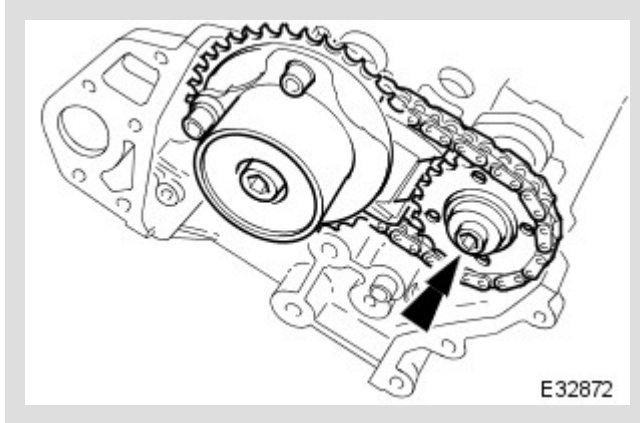

Loosen the bolt which secures the sprocket to the exhaust camshaft.

15.

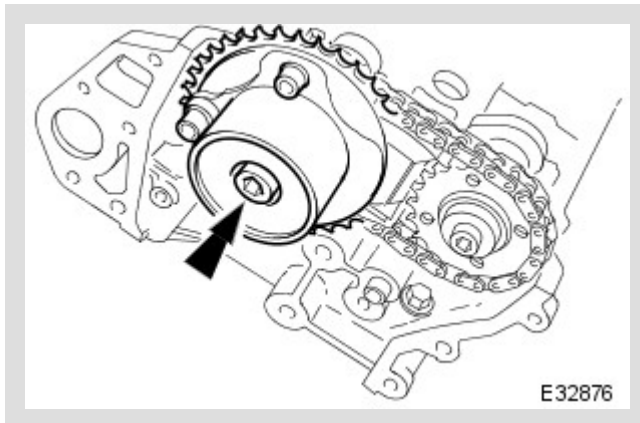

Loosen the bolt which secures the VVT unit..

Do not tamper with the three bolts which secure the VVT mechanism to the sprockets. It is sealed at the factory to the correct valve timing specification for the engine and is supplied only as a complete unit.

16. Remove the LH primary timing chain tensioner. For additional information, refer to: [Primary Timing Chain Tensioner LH](#) (303-01 Engine, In-vehicle Repair).

17.

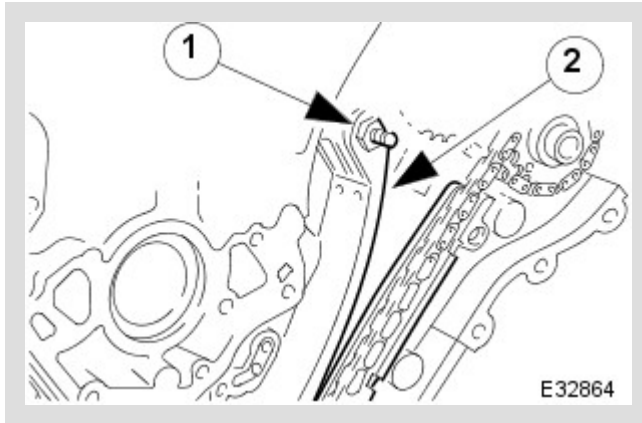

Remove the primary chain tensioner blade.

1. Remove the pivot bolt which secures the tensioner blade.
2. Remove the tensioner blade.

18. Reposition the VVT unit along the cam journal to allow the chain to clear the head casting.

Disconnect the primary chain from the VVT unit and reposition it against the crankshaft sprocket.

19.

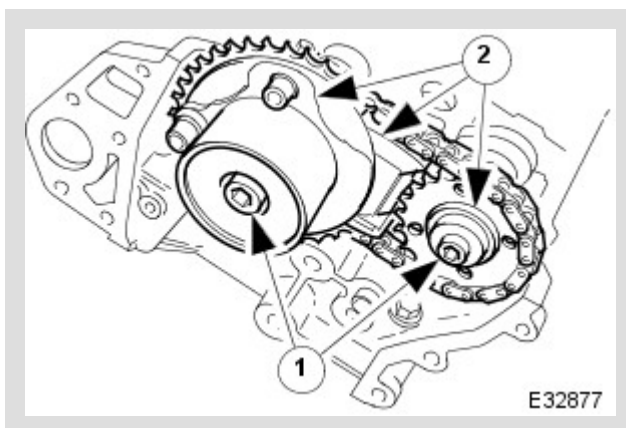

Remove the VVT unit.

1. Remove the securing bolt from the VVT unit and the exhaust cam sprocket.
2. Remove the VVT unit, exhaust sprocket and secondary chain as an assembly (release the chain from the tensioner which is still secured to the cylinder head).

Remove the secondary chain from the VVT unit and the sprocket.

20. Clean and inspect all relevant components.

## INSTALLATION

1.

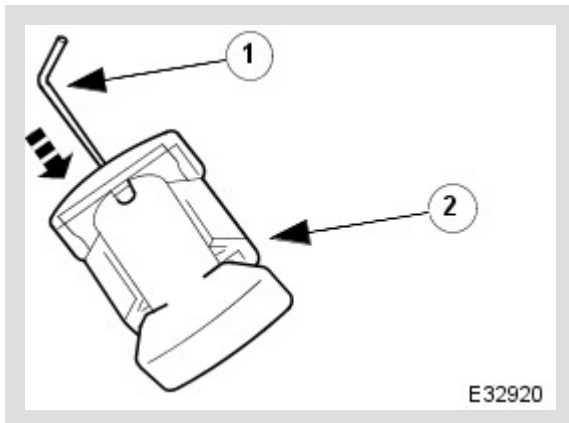

Push the tensioner piston (secondary chain) into the body to provide clearance for installing.

1. Insert a thin rigid wire through the hole in the end of the tensioner piston to displace the ball from the non-return valve seat.
2. With the wire in position, press the piston fully into the tensioner body.

Remove the wire.

2.

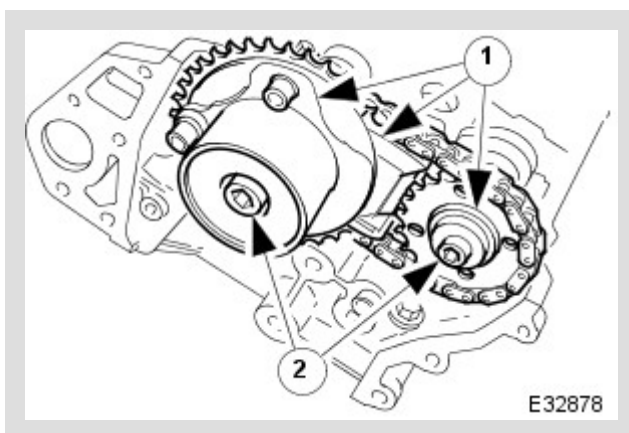

Install the VVT unit to the engine.

Assemble the VVT unit, the exhaust camshaft sprocket and the secondary chain, in preparation for installing to the engine.

1. Install the above assembly to the camshafts with the chain correctly positioned over the tensioner; VVT unit to the inlet and the sprocket to the exhaust.
2. Install, but do not tighten, each bolt which secures the VVT unit and the exhaust sprocket to the camshafts. Allow the VVT unit sufficient space to install the primary chain, in a later operation.



3.

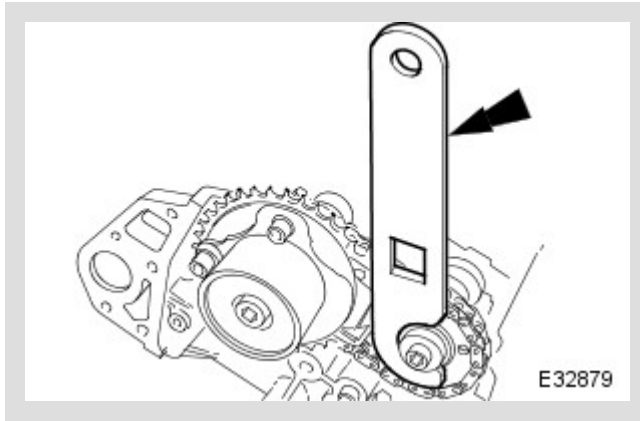

Install the chain tensioning tool JD 217 to the exhaust camshaft sprocket.

Reposition the sprocket (and the VVT unit) for the most advantageous position for use of the tool.

Remove the tool.

4.

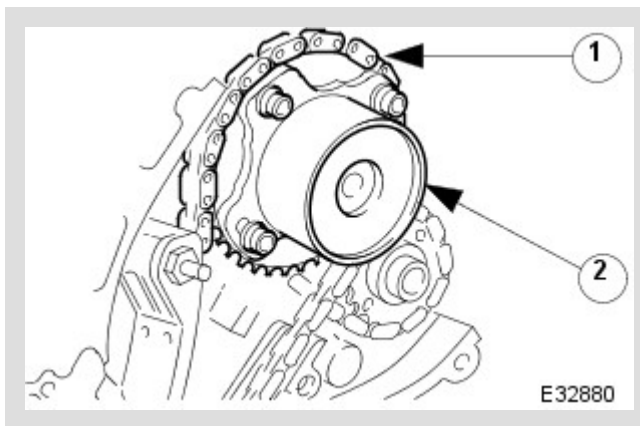

Install the primary timing chain.

1. Lift the primary chain and position it over the VVT unit sprocket (the VVT unit must be pulled forward to clear the cylinder head casting). There must be no slack on the drive side of the primary chain and the VVT unit must not be rotated on the camshaft.
2. Slide the VVT unit fully on to the camshaft.

5.

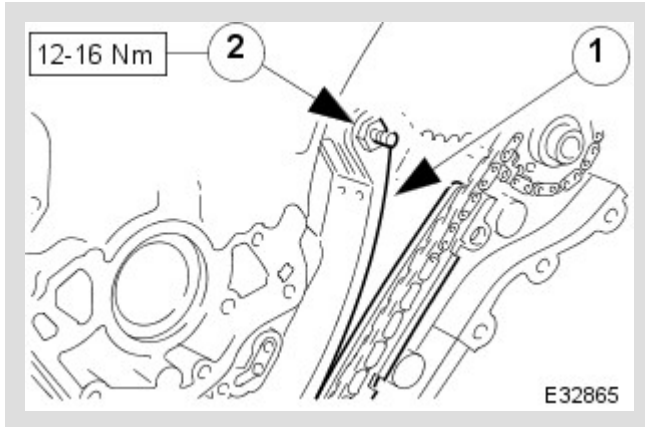

Install the primary chain tensioner blade.

1. Position the tensioner blade to the cylinder block.
2. Install the retaining / pivot bolt and tighten it to 14 Nm.

6.

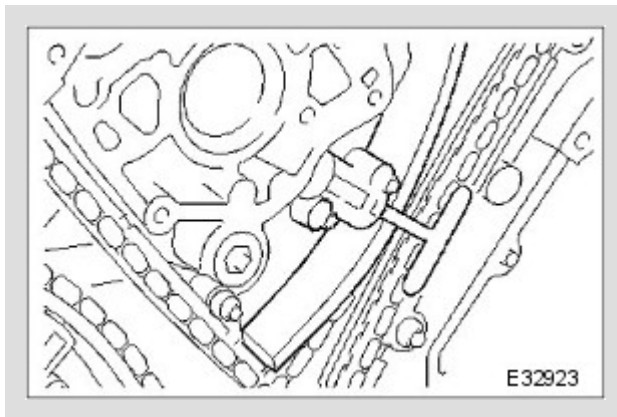

Install the primary chain tensioner assembly. Refer to Operation 12.65.55 in this Section. For additional information, refer to: [Primary Timing Chain Tensioner LH](#) (303-01 Engine, In-vehicle Repair).

Use a wedge JD 218 (or two if required) between the primary chain tensioner and tensioner blade, to take up the slack in the chain.

7.

**ⓘ CAUTION:**

Make sure that a new bolt is installed.

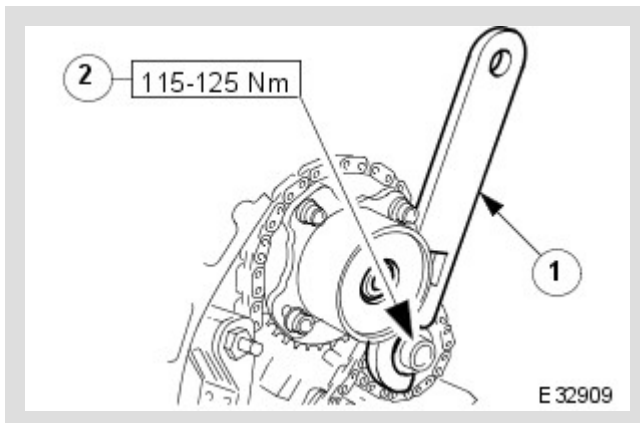

Tighten the exhaust camshaft sprocket securing bolt.

1. Install the chain tensioner tool JD 217 to the sprocket holes.

Apply force to the tool in an anti-clockwise direction to tension the chain on its drive side.

2. Whilst applying the opposing force to the sprocket and chain, tighten the sprocket securing bolt to 20 Nm + 90°.

8.

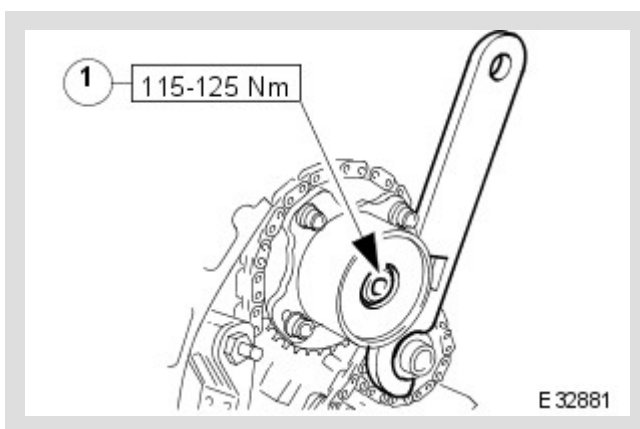

Tighten the VVT unit securing bolt.

1. Whilst still applying the opposing force to the sprocket and chain (using JD 217), check that the wedges are still in place, tighten the VVT unit securing bolt to 20 Nm + 90°.

Remove the chain tensioning tool and the wedge(s).

9. Remove the camshaft locking tool JD 215.

10. Raise the vehicle on the ramp.

11. Remove the crankshaft setting tool JD 216.

12.

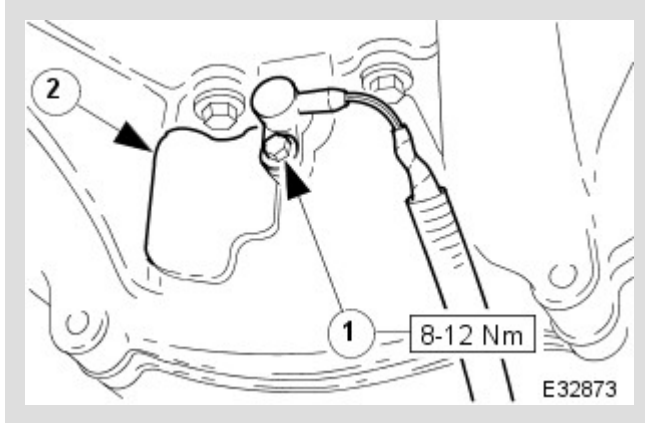

Install the crankshaft position sensor.

1. Install the sensor to the flywheel housing and install the securing bolt. Tighten to 10 Nm.
2. Install the access grommet to the housing.

13. Lower the ramp.

14. Install the LH variable camshaft timing oil control unit housing. For additional information, refer to: [Variable Camshaft Timing Oil Control Unit Housing LH](#) (303-01 Engine, In-vehicle Repair).

15. Install the engine front cover. For additional information, refer to: [Engine Front Cover](#) (303-01 Engine, In-vehicle Repair).

16. Move the engine compartment cover from the service position and connect the gas struts.

17. Remove the paint protection sheets and close the cover.

18. Connect the battery and install the battery cover. For additional information, refer to: [Battery Connect](#) (414-01 Battery, Mounting and Cables, General Procedures).

**PUBLISHED: 11-MAY-2011**  
**1997.0 X100, 414-01**

**BATTERY, MOUNTING AND CABLES**

**BATTERY CONNECT** [G222938]

## GENERAL PROCEDURES

1.

### NOTE:

Whether one, or both, cables are disconnected, a minimum of 30 seconds MUST elapse between disconnection of the FIRST cable and reconnection of the LAST cable. A clean final connection must be made; do not allow temporary contact.

Connect the battery terminal(s).

2. Reset the clock.

3. Enter the radio security code. If necessary, refer to the Sound System Handbook.

4. Cycle (both) door drop glass up and down to establish the upper and lower datum points.

Switch the ignition ON .

Lower the glass to the stop and hold the switch in the DOWN position for a further five seconds.

Raise the glass fully and hold the switch in the UP position for a further five seconds.

5. Switch the ignition OFF .

**PUBLISHED: 11-MAY-2011**  
**1997.0 X100, 303-01**

## ENGINE

# ENGINE FRONT COVER (G222793)

## IN-VEHICLE REPAIR

12.65.01

**TIMING  
COVER -  
RENEW**

**ALL  
DERIVATIVES**

4.40

**USED WITHINS**

12.65.01

**TIMING  
COVER -  
RENEW**

**ALL  
DERIVATIVES**

4.40

**USED WITHINS**

## REMOVAL

1. Open the engine compartment and fit paintwork protection sheets.

2. Set the bonnet to the service access position.

3.

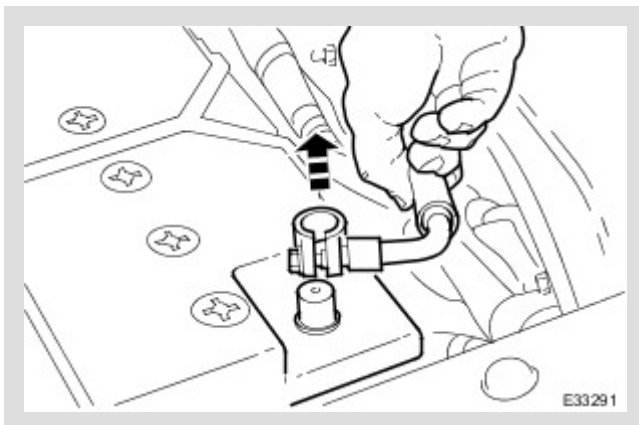

Disconnect the battery ground cable.

Remove the battery cover.

4. Drain the coolant from the radiator. Refer to Operation 26.10.01.

5.

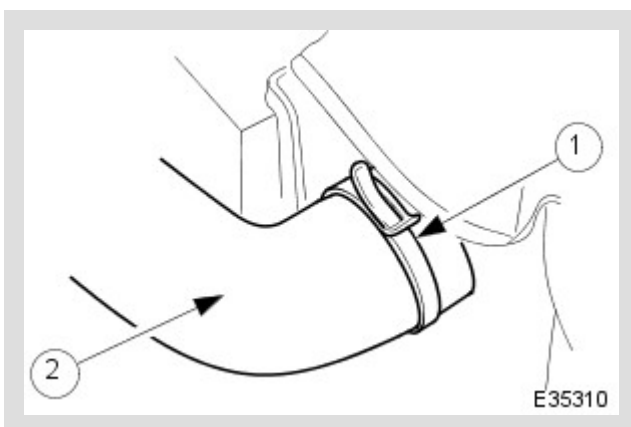

Disconnect the radiator top hose.

1. Slacken the hose retaining clip and reposition the clip along the hose.

2. Disconnect the hose from the radiator.

6.

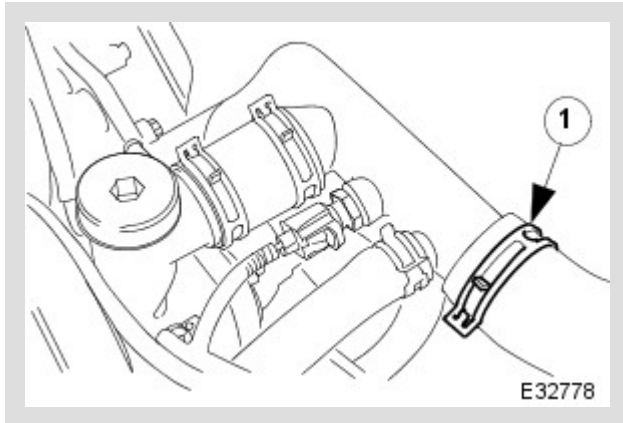

Disconnect the top hose from the coolant outlet pipe.

1. Release and reposition the hose clip, and disconnect the top hose.

7.

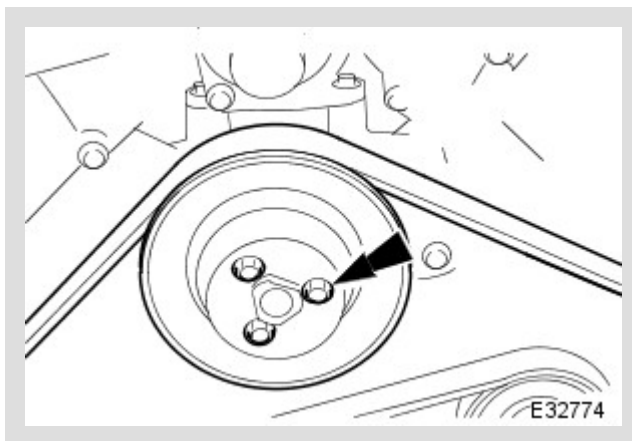

Slacken the three screws which secure the water pump pulley.

8.

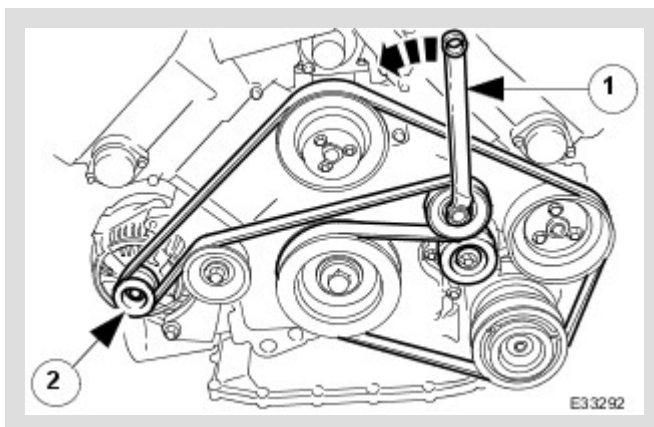

Remove the drive belt from the generator and accessory drive.

1. Use a spanner e.g. Churchill JD-230 or Snap On XDHM 1415, on the centre bolt of the belt tensioner idler pulley, to turn the adjuster assembly to the left against spring tension.
2. Whilst holding the tensioner against spring tension, remove the drive belt from the generator pulley. Release the tensioner slowly and remove the spanner.  
Disconnect the belt from the other pulleys and remove it..

9.

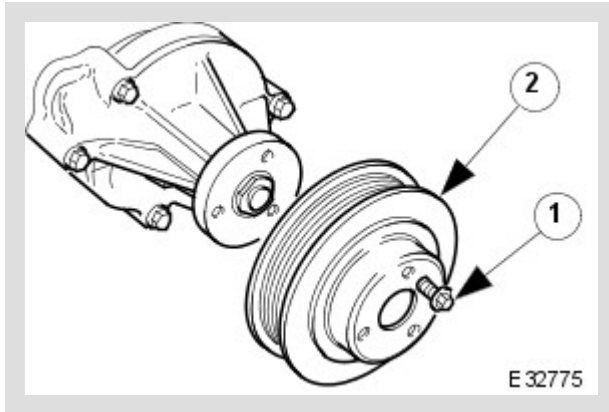

Remove the pulley from the water pump.

1. Remove the pulley securing screws.
2. Remove the pulley from the water pump.

10. Remove the belt tensioner assembly, from the Front Accessory Drive. Refer to Operation 12.10.41.

11. Remove the idler pulley, from the Front Accessory Drive. Refer to Operation 12.10.43.

12. Remove the crankshaft damper. Refer to Operation 12.21.09.

13. Carefully remove the engine covers, taking care not to damage the plastic fixings or the rubber inserts.

14.

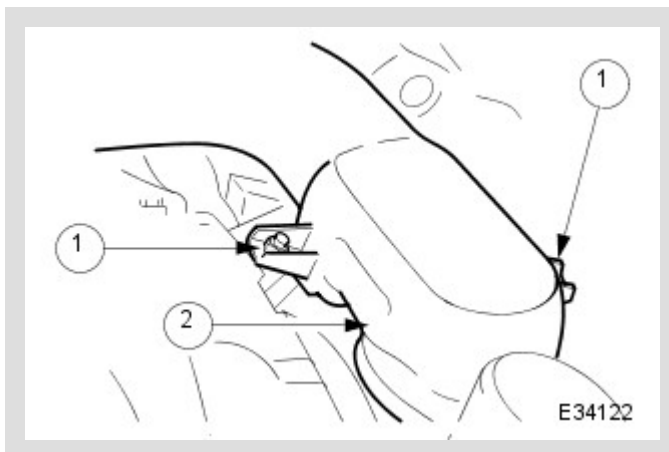

Disconnect the intake tube from the throttle body.

1. Remove the two bolts which secure the intake tube to the throttle body.
2. Disconnect the intake tube from the throttle body.



15.

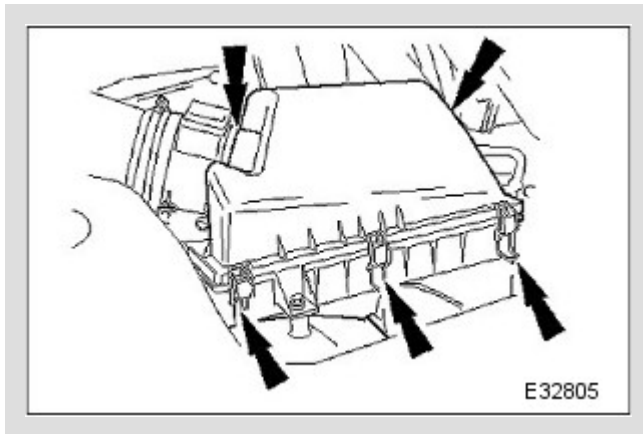

Disconnect the air cleaner cover.

Release the five clips which secure the air cleaner cover.

16. Disconnect the air flow meter multi-plug.

17.

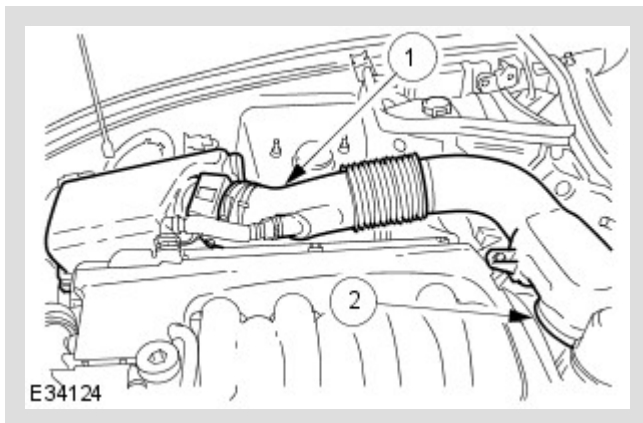

Remove the intake tube / air flow meter / air cleaner cover assembly.

1. Remove the intake tube / air flow meter / air cleaner cover assembly.

2. Remove and discard the rubber seal; air intake tube to throttle body.

18. Remove the purge valve, from the evaporative control system. Refer to Operation 17.45.01.

19. Remove the on-plug ignition coils. Refer to Operation 18.20.41 and 18.20.42.

20. Remove the camshaft covers. Refer to Operations 12.29.43 and 12.29.44.

21. Remove the variable valve timing solenoids. Refer to Operation 18.30.63.

22.

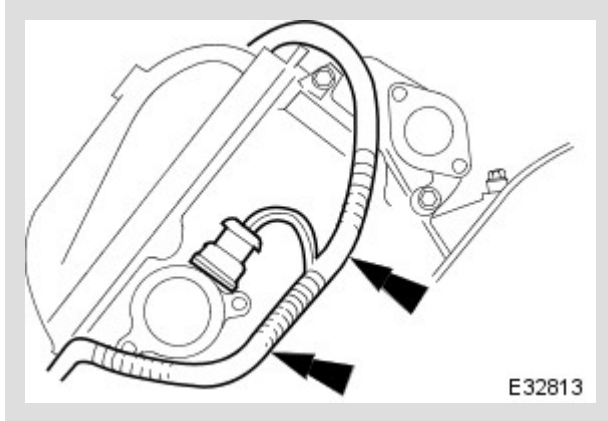

Disconnect the engine harness retaining clips from the timing cover.

23.

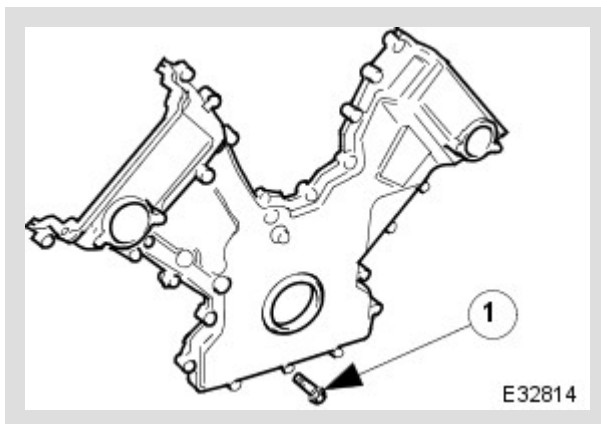

Remove the timing cover securing bolts.

1. Remove the twenty-four bolts which secure the timing cover.

24.



Remove the timing cover, step 1.

Ease the cover towards the front of the vehicle to separate it from the engine.

25.



Remove the timing cover, step 2.

Standing at the right hand side of the vehicle, rotate and manoeuvre the cover upwards to clear the water pump and hoses.

26.

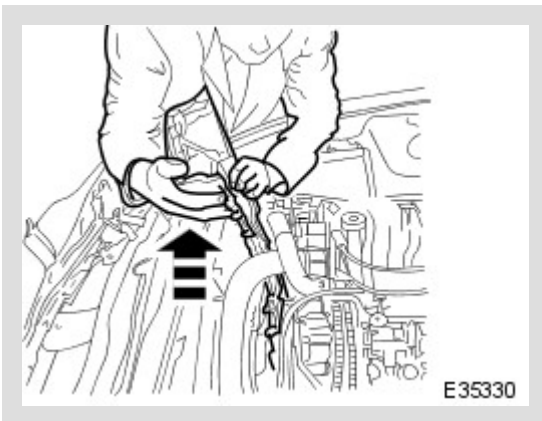

Remove the timing cover, step 3.

Lift the cover clear of the engine compartment.

27.

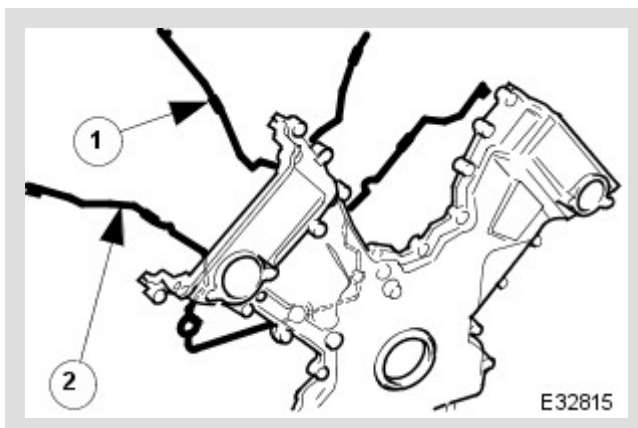

Remove and discard the inner and outer seals from the timing cover.

1. Remove the seal from the inner groove on the face of the timing cover.
2. Remove the seal from the outer groove on the face of the timing cover.

28. Clean all parts and mating faces.

## INSTALLATION

1.

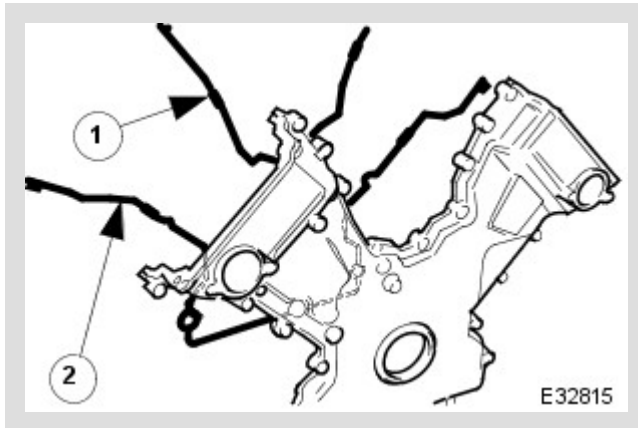

Fit new seals to the timing cover.

1. Fit and fully locate, a new seal to the inner groove on the face of the timing cover.
2. Fit and fully locate, a new seal to the outer groove on the face of the timing cover.

2.

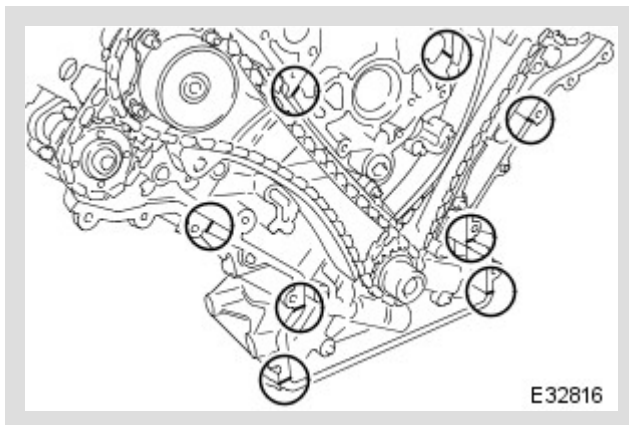

Apply sealant to the eight joints on the engine face.

Sealant beads to be 3mm diameter and 12mm long. Cut the nozzle of the sealant tube to produce a 3mm bead. (Fit and tighten the securing bolts within twenty minutes of sealant application)

3.

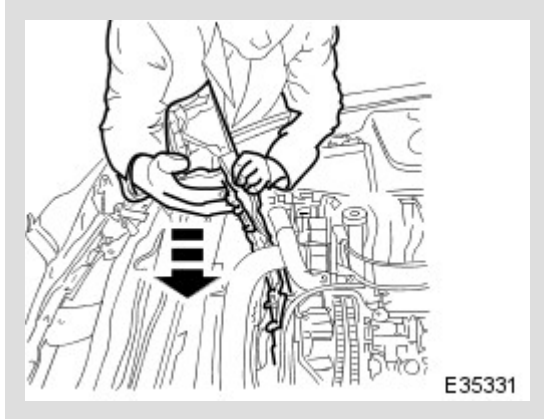

Refit the timing cover, step 1.

Lower the cover into the engine compartment, to its approximate position.

4.



Refit the timing cover, step 2.

Standing at the right hand side of the vehicle, rotate and manoeuvre the cover downwards to clear the water pump and hoses.

5.



Refit the timing cover, step 3.

Ease the cover towards the engine and locate it directly onto the dowels so that the gaskets or sealant are not smeared.

6.

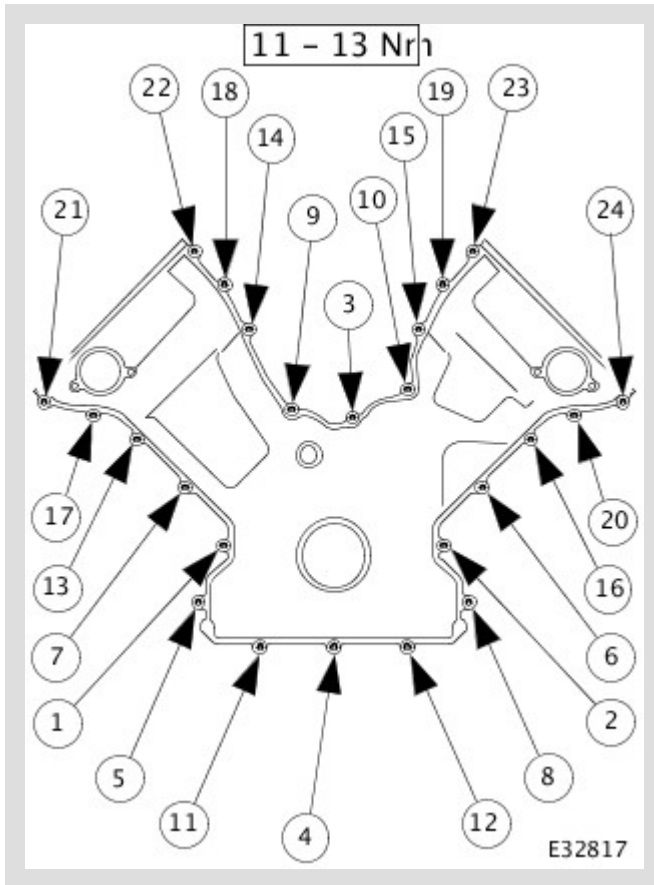

Fit and tighten the securing bolts in the correct order. Tighten to 11-13 Nm.

7.

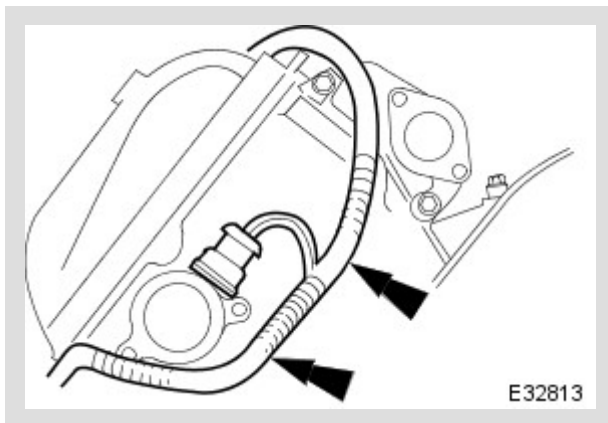

Reposition and secure the engine harness clips to the timing cover.

8. Refit the variable valve timing solenoids. Refer to Operation 18.30.63.

9. Refit the camshaft covers. Refer to Operations 12.29.43 and 12.29.44.

10. Refit the on-plug ignition coils and coil covers. Refer to Operation 18.20.41 and 18.20.42.

11. Refit the purge valve. Refer to Operation 17.45.01.

12.

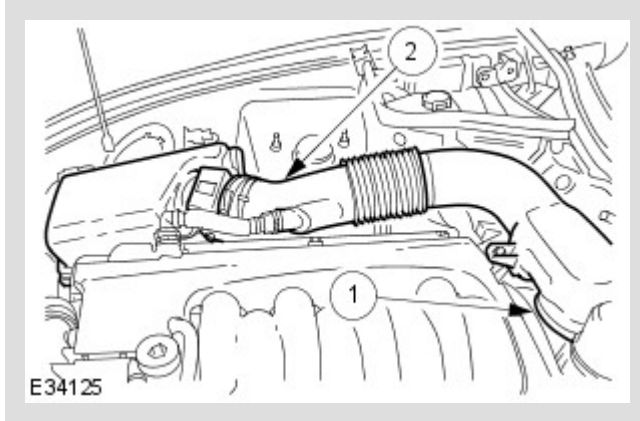

Fit the intake tube / air flow meter / air cleaner cover assembly.

1. Fit a new rubber seal; air intake tube to throttle body.
2. Fit the intake tube / air flow meter / air cleaner cover assembly.

13.

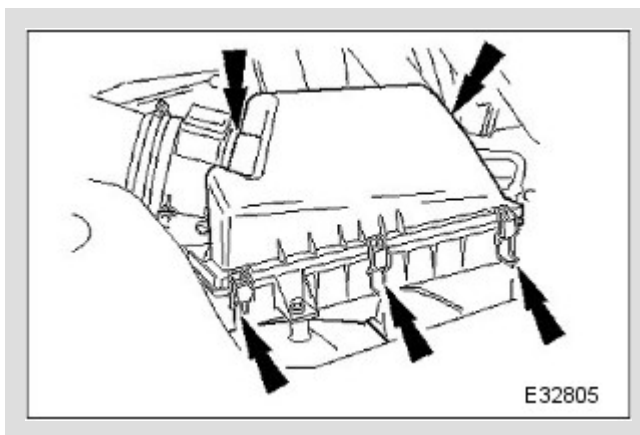

Reconnect the air cleaner cover.

Fit the five clips which secure the air cleaner cover.

14.

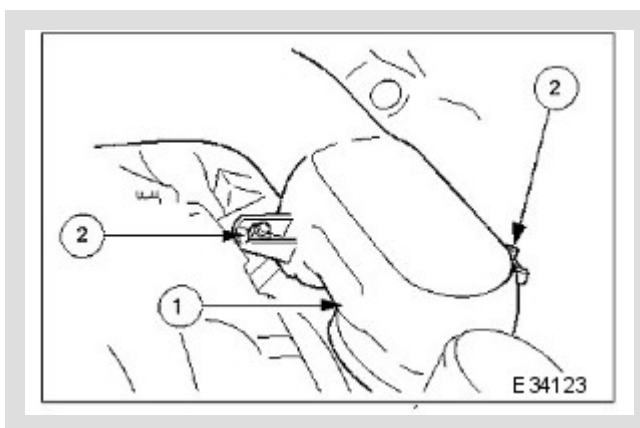

Connect the intake tube to the throttle body.

1. Connect the intake tube to the throttle body.
2. Fit the two bolts which secure the intake tube to the throttle body.

---

15. Reconnect the air flow meter multi-plug.

---

16. Refit the engine covers.

---

17. Refit the crankshaft damper. Refer to Operation 12.21.09.

---

18. Refit the idler pulley, to the Front Accessory Drive. Refer to Operation 12.10.43.

---

19. Refit the belt tensioner assembly, to the Front Accessory Drive. Refer to Operation 12.10.41.

---

20.

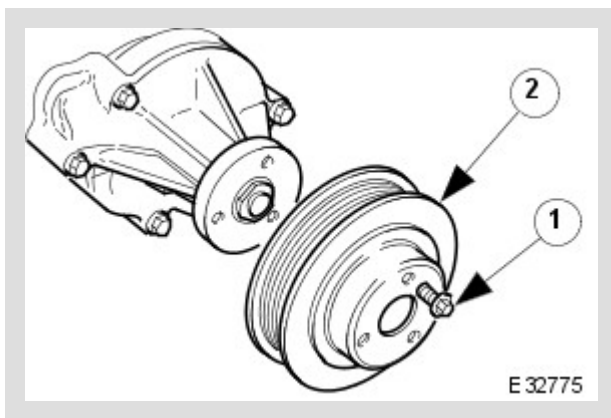

Refit the pulley to the water pump.

1. Refit the pulley to the water pump.
2. Fit the pulley securing screws. Tighten as far as possible; then to the correct torque after the belt has been fitted.



21.

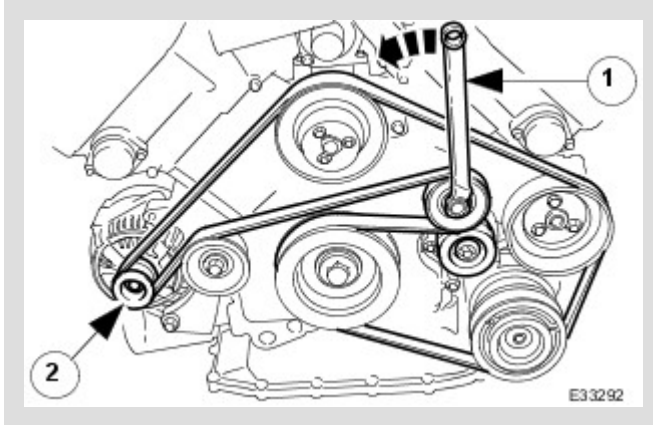

Refit the drive belt to the generator and accessory drive.

Locate the belt around the pulleys, except the generator pulley.

1. Use a spanner e.g. Churchill JD-230 or Snap On XDHM 1415, on the centre bolt of the belt tensioner idler pulley, to turn the adjuster assembly to the left against spring tension.
2. Whilst holding the tensioner against spring tension, connect the drive belt to the generator pulley. Release the tensioner slowly and remove the spanner.

22.

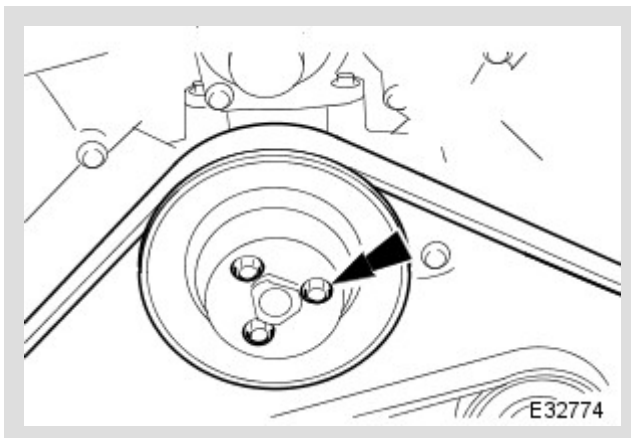

Tighten the three screws which secure the water pump pulley, to 10-14 Nm.

23.

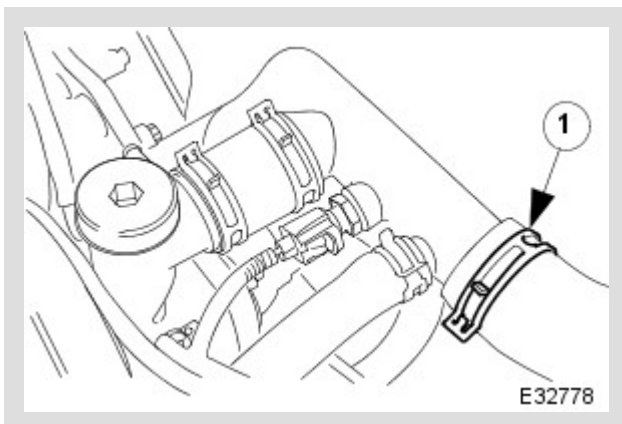

Connect the top hose to the coolant outlet pipe.

1. Connect the top hose. Reposition the hose clip and tighten.

24.

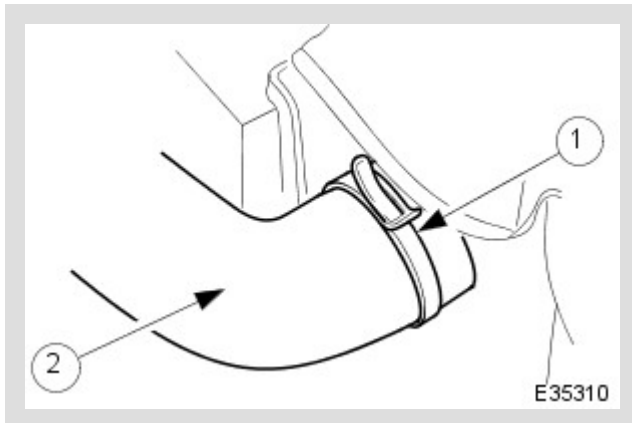

Connect the radiator top hose.

1. Connect the hose to the radiator.
2. Reposition the clip along the hose and tighten the clip.

25. Reset the bonnet to the normal position and connect the gas struts.

26. Connect the battery and fit the battery cover.

Refer to the Battery Reconnection Procedure 86.15.15.

27. Refill the cooling system. Refer to Operator 26.10.01.

28. Remove the paintwork protection sheets and close the engine compartment.

PUBLISHED: 11-MAY-2011  
1997.0 X100, 303-01

## ENGINE

# VARIABLE CAMSHAFT TIMING OIL CONTROL UNIT HOUSING LH (G222826)

IN-VEHICLE REPAIR

12.65.52	VARIABLE VALVE TIMING BUSHING CARRIER ASSEMBLY - BANK 2 - RENEW	ALL DERIVATIVES	4.50	USED WITHINS
----------	--	--------------------	------	--------------

12.65.52

VARIABLE  
VALVE  
TIMING  
BUSHING  
CARRIER  
ASSEMBLY -  
BANK 2 -  
RENEW

ALL  
DERIVATIVES

4.50

USED WITHINS

## REMOVAL

1. Open the engine compartment and fit paintwork protection sheets.

2. Set the engine compartment cover to the service access position.

3.

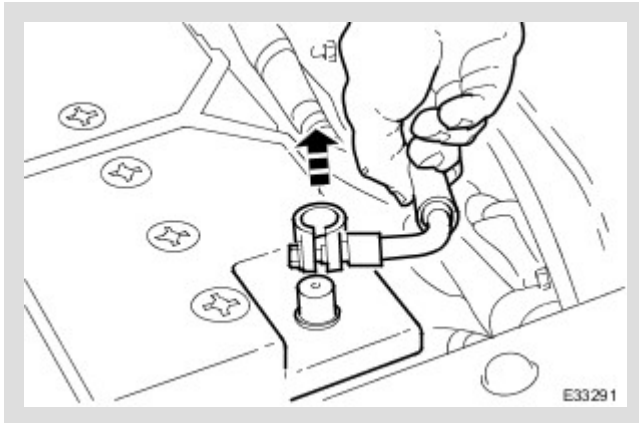

Disconnect the battery ground cable.

Remove the battery cover.

4. Remove the Timing Cover. Refer to Operation 12.65.01 in this Section.

5.

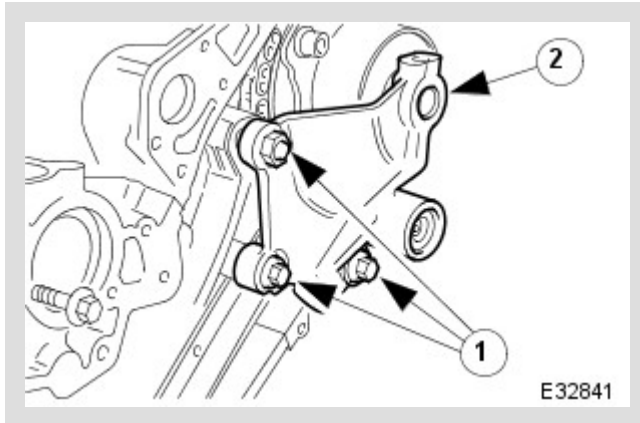

Remove the VVT bush carrier.

1. Remove the two bolts and one nut which secure the carrier to the cylinder block.
2. Release the carrier from the two ring dowels and remove it.

6.

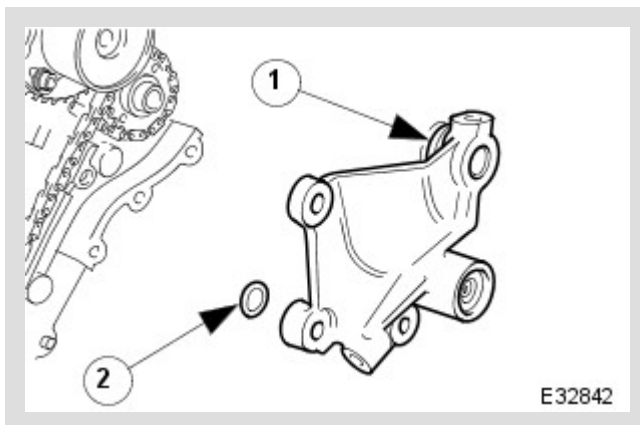

Remove the seals from the bush carrier.

1. Remove the sealing ring (scarf jointed) from the carrier bush groove.
2. Remove the O-ring from the carrier oil-way recess.

7. Clean and inspect all relevant components.

## INSTALLATION

1.

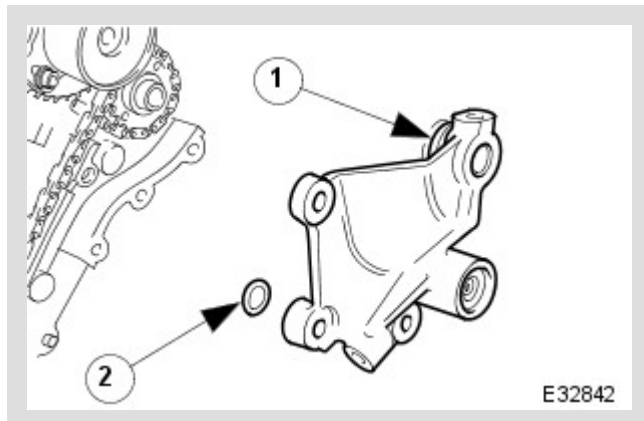

Fit new seals to the bush carrier.

1. Fit the new sealing ring (scarf jointed) to the carrier bush groove.
2. Fit a new O-ring to the carrier oil-way.

2.

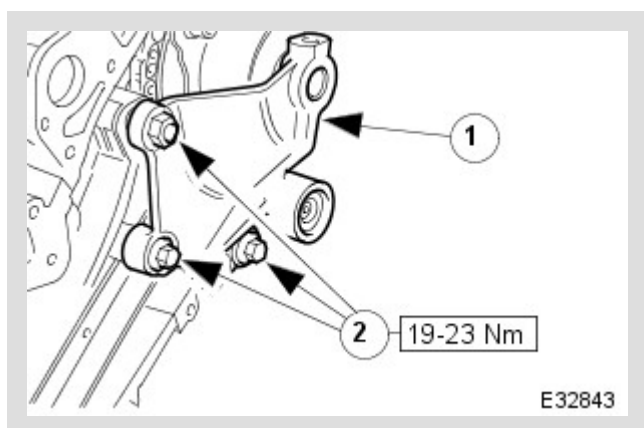

Fit the bush carrier to the cylinder block.

Lubricate the seal (scarf jointed) and the bush.

1. Fit the bush carrier assembly.

Check that the seals are in place and that the ring dowels are engaged squarely. Fully locate the assembly as much as possible by hand pressure.

2. Fit the two securing bolts and one nut. Tighten to 19-23 Nm.

3. Refit the Timing Cover. Refer to Operation 12.65.01 in this Section.

4. Move the engine compartment cover from the service position and connect the gas struts.

5. Remove the paint protection sheets and close the cover.

6. Connect the battery and fit the battery cover.

Refer to the Battery Reconnection Procedure 86.15.15.

**PUBLISHED: 11-MAY-2011**  
**1997.0 X100, 303-01**

## ENGINE

# PRIMARY TIMING CHAIN TENSIONER LH (G222811)

### IN-VEHICLE REPAIR

12.65.55	TIMING CHAIN TENSIONER - PRIMARY - BANK 2 - RENEW	ALL DERIVATIVES	4.50	USED WITHINS
----------	--	--------------------	------	--------------

12.65.55	TIMING CHAIN TENSIONER - PRIMARY - BANK 2 - RENEW	ALL DERIVATIVES	4.50	USED WITHINS
----------	--	--------------------	------	--------------

### REMOVAL

1. Open the engine compartment and fit paintwork protection sheets.

2. Set the engine compartment cover to the service access position.

3.

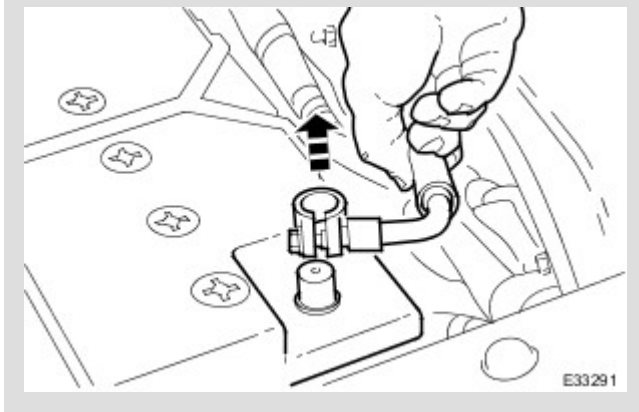

Disconnect the battery ground cable.

Remove the battery cover.

4. Remove the Timing Cover. Refer to Operation 12.65.01 in this Section.

5.

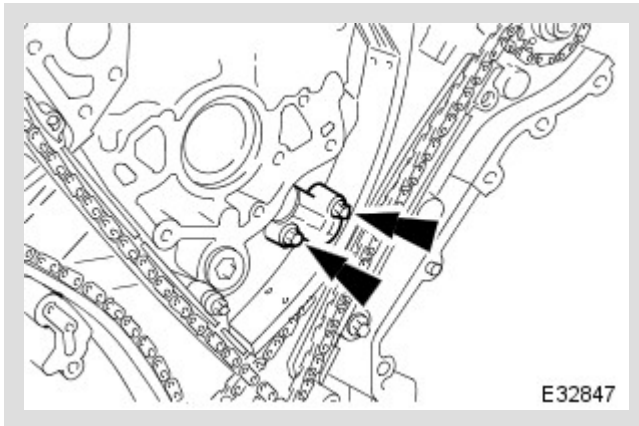

Remove the primary chain tensioner bolts.

6.

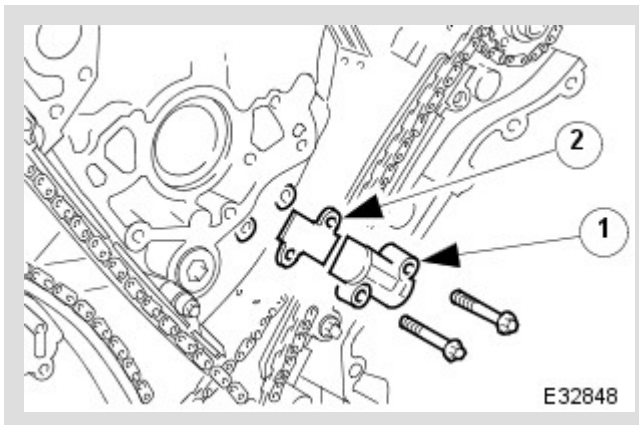

Remove the tensioner assembly.

1. Remove the tensioner.

2. Remove the tensioner back-plate.

7. Clean and inspect all relevant components.

## INSTALLATION

1.

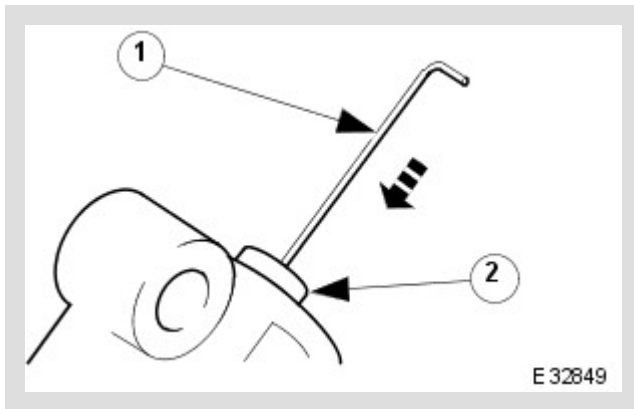

Push the tensioner piston into the body to provide clearance for fitting.

1. Insert a thin rigid wire through the hole in the end of the tensioner piston to displace the ball from the non-return valve seat.
2. With the wire in position, press the piston fully into the tensioner body.

Remove the wire.

2.

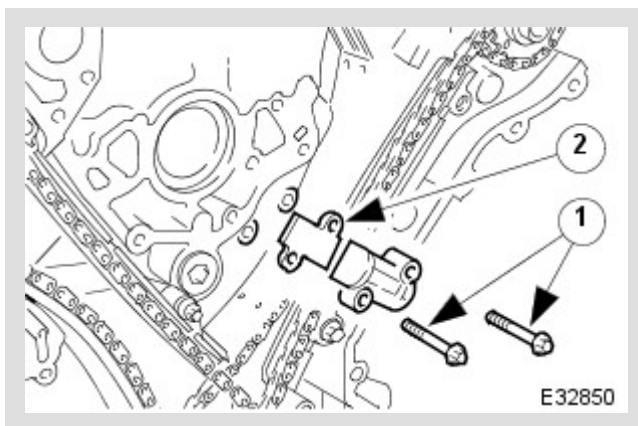

Assemble the tensioner.

1. Fit the two mounting bolts to the tensioner.
2. Locate the tensioner back-plate to the two bolts.



3.

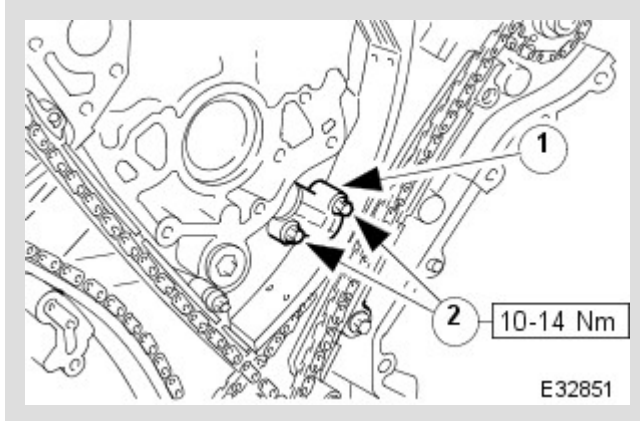

Fit the tensioner to the cylinder block.

1. Position and align the tensioner to the cylinder block and to the mating slot on the rear face of the tensioner blade.
2. Fit and tighten the two bolts to 10-14 Nm.

4. Refit the Timing Cover. Refer to Operation 12.65.01 in this Section.

5. Move the engine compartment cover from the service position and connect the gas struts.

6. Remove the paint protection sheets and close the cover.

7. Connect the battery and fit the battery cover.

Refer to the Battery Reconnection Procedure 86.15.15.